

05354400 - LT-A VDI40 138-32 R 2:1 H100

Type	LT-A Tool holder angle 90°
Mounting	VDI 40
Tool output	Shell-Mill DIN138 32
Coolant	External coolant
Direction of rotation	r1 ↻ r2 ↻
Max speed [rpm]	in 6000 / out 3000
Max torque [Nm]	in 70 / out 140
Ratio	2:1
H [mm]	100
H1 [mm]	43
Accessories	N.A.
Notes	N.A.
Mounting tips	Secondary spindle only

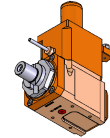

ATTENTION: CHECK THE ORIENTATION OF THE VDI TEETH

Always check live tool dimensions on the turret

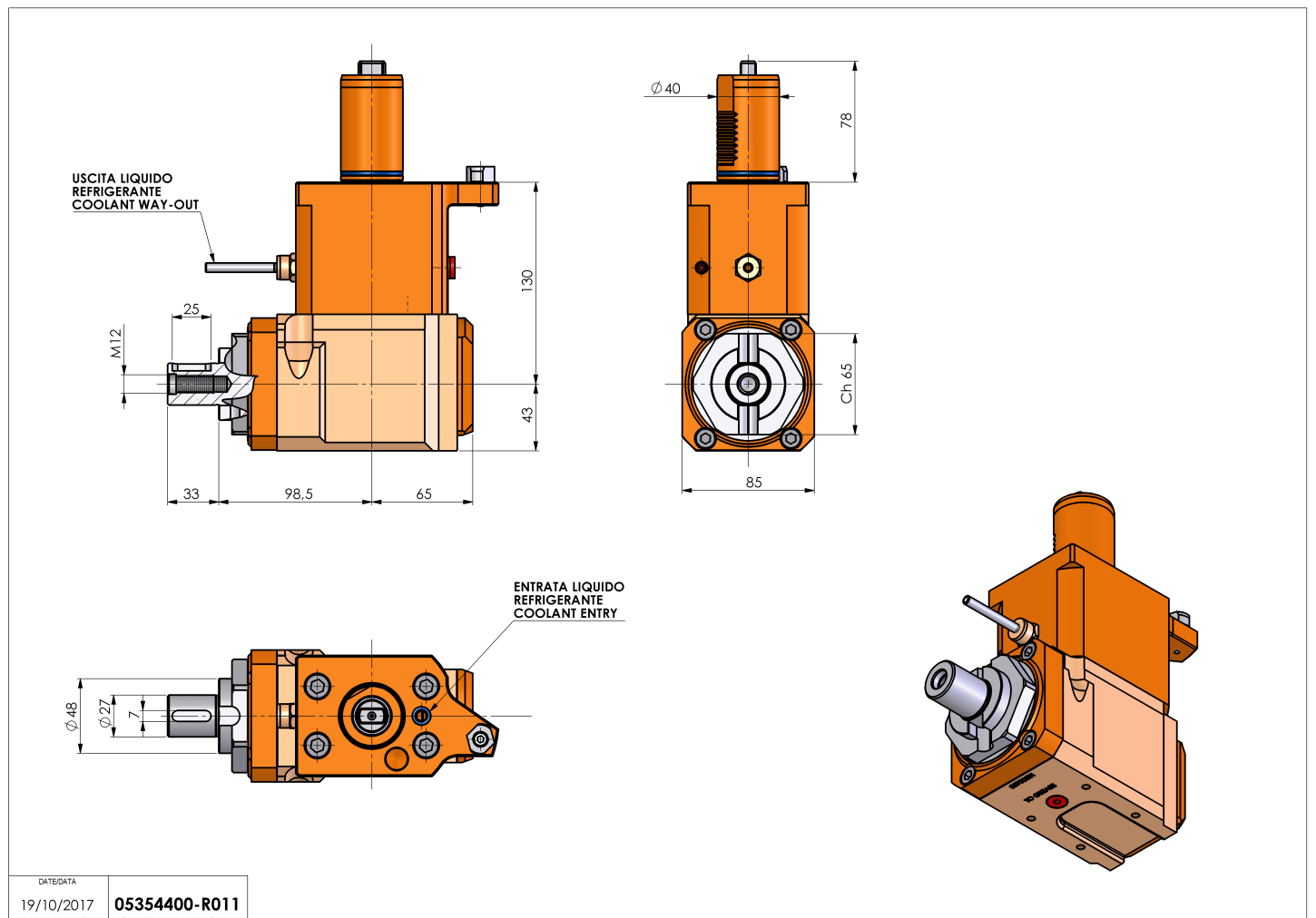

DATE/DATE	19/10/2017	05354400-R011
-----------	------------	---------------

Subject to technical changes