

05353300 - LT-SVDI40ER20FOFS78 1:3KRH88MZ

Type	LT-S OFS Tool holder straight offset
Mounting	VDI 40
Tool output	Collet nut ER 20 F - internal nut
Coolant	External coolant
Offset [mm]	78
Direction of rotation	r1 ↻ r2 ↻
Max speed [rpm]	in 5000 / out 15000
Max torque [Nm]	in 50 / out 14
Ratio	1:3
H [mm]	89
Accessories	N.A.
Notes	N.A.
Mounting tips	Main spindle only

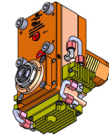

ATTENTION: CHECK THE ORIENTATION OF THE VDI TEETH

Always check live tool dimensions on the turret

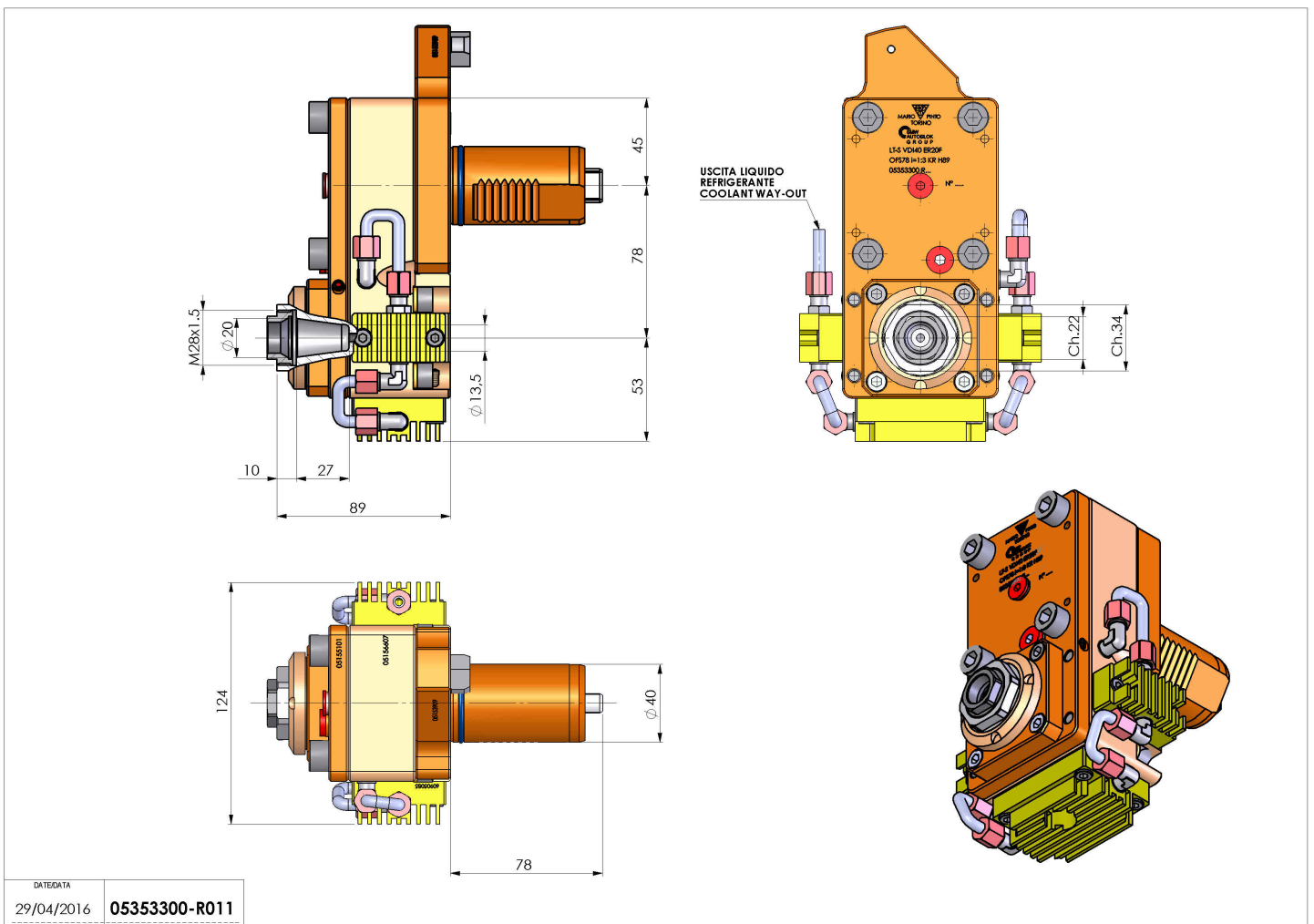

DATE/DATE	05353300-R011
29/04/2016	

Subject to technical changes