

# 05352800 - LT-S D80 ER20F OF78RF1:3H101MZ

<b>Type</b>	LT-S OFS Tool holder straight offset
<b>Mounting</b>	CYLINDRICAL SHANK 80
<b>Tool output</b>	Collet nut ER 20 F - internal nut
<b>Coolant</b>	Internal coolant
<b>Offset [mm]</b>	78
<b>Direction of rotation</b>	r1 ↻ r2 ↻
<b>Max speed [rpm]</b>	in 5000 / out 15000
<b>Max torque [Nm]</b>	in 50 / out 14
<b>Ratio</b>	1:3
<b>H [mm]</b>	101,5
<b>Max pressure [bar]</b>	20
<b>Accessories</b>	N.A.
<b>Notes</b>	N.A.
<b>Mounting tips</b>	N.A.

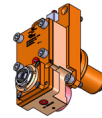

Always check live tool dimensions on the turret

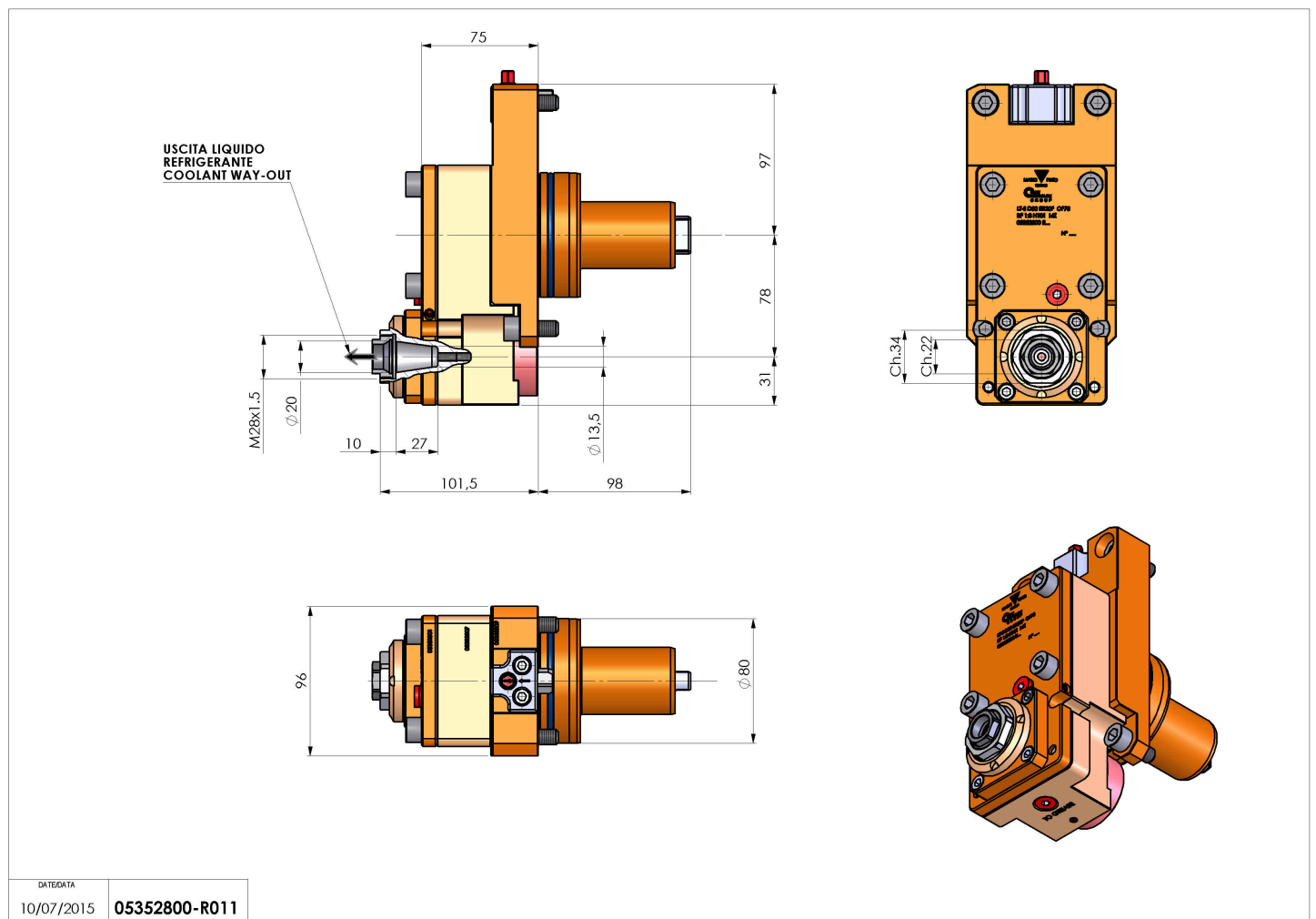

Subject to technical changes