

# 05352300 - LT-A D80 WELDON20 RF H100 MZ

Type	LT-A Tool holder angle 90°
Mounting	CYLINDRICAL SHANK 80
Tool output	Weldon 20 DIN1835B
Coolant	Internal coolant
Direction of rotation	r1 ↻ r2 ↻
Max speed [rpm]	6000
Max torque [Nm]	80
Ratio	1:1
H [mm]	100
H1 [mm]	43
Max pressure [bar]	20
Accessories	N.A.
Notes	N.A.
Mounting tips	N.A.

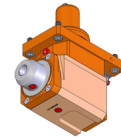

Always check live tool dimensions on the turret

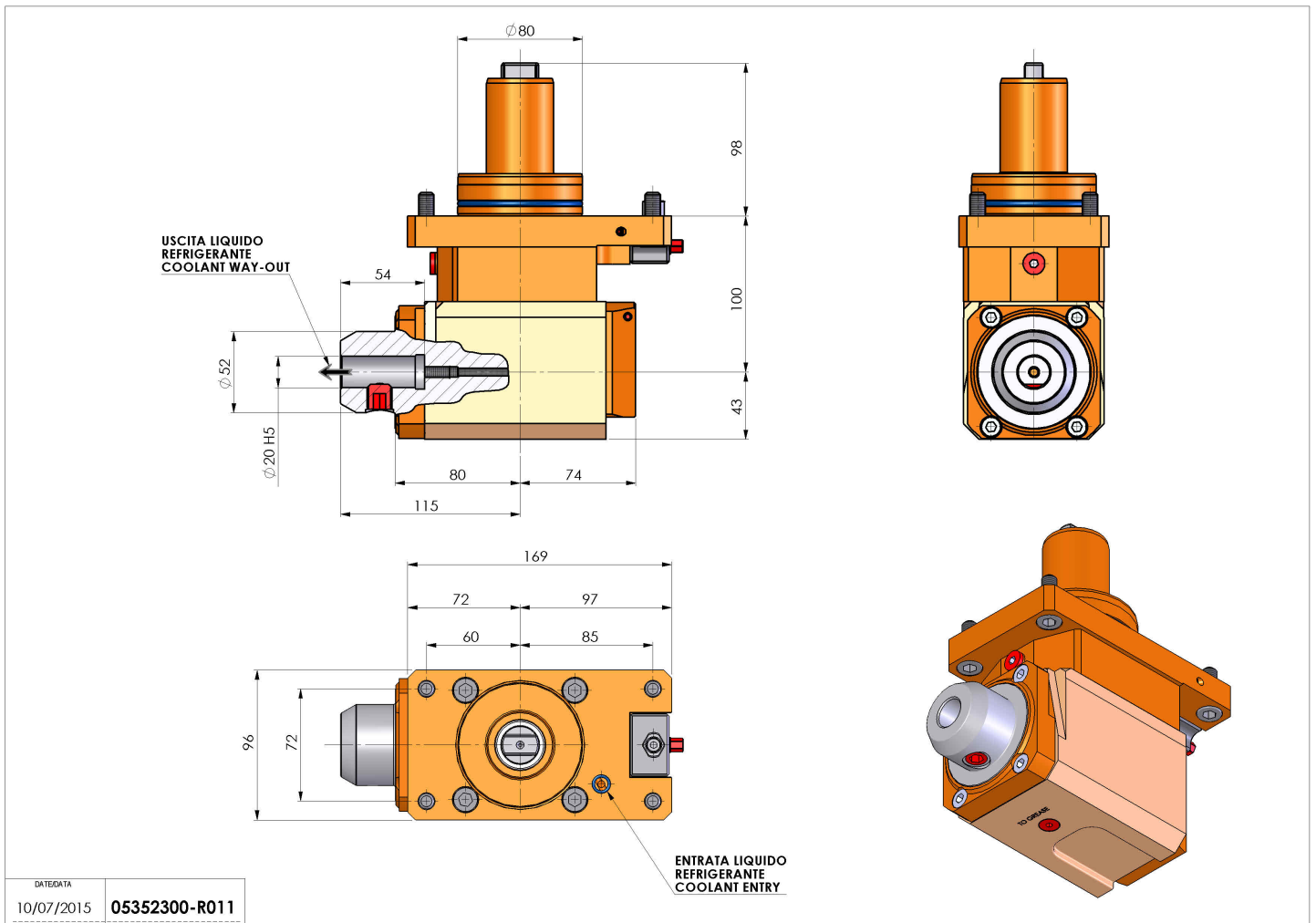

DATE/DATE: 10/07/2015 05352300-R011

Subject to technical changes