

05351900 - LT-S D80 ER32F OFS100 H96 MZ

Type	LT-S OFS Tool holder straight offset
Mounting	CYLINDRICAL SHANK 80
Tool output	Collet nut ER 32 F - internal nut
Coolant	External coolant
Offset [mm]	100
Direction of rotation	r1 ↻ r2 ↻
Max speed [rpm]	6000
Max torque [Nm]	80
Ratio	1:1
H [mm]	95,5
Accessories	N.A.
Notes	N.A.
Mounting tips	N.A.

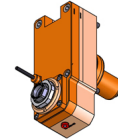

Always check live tool dimensions on the turret

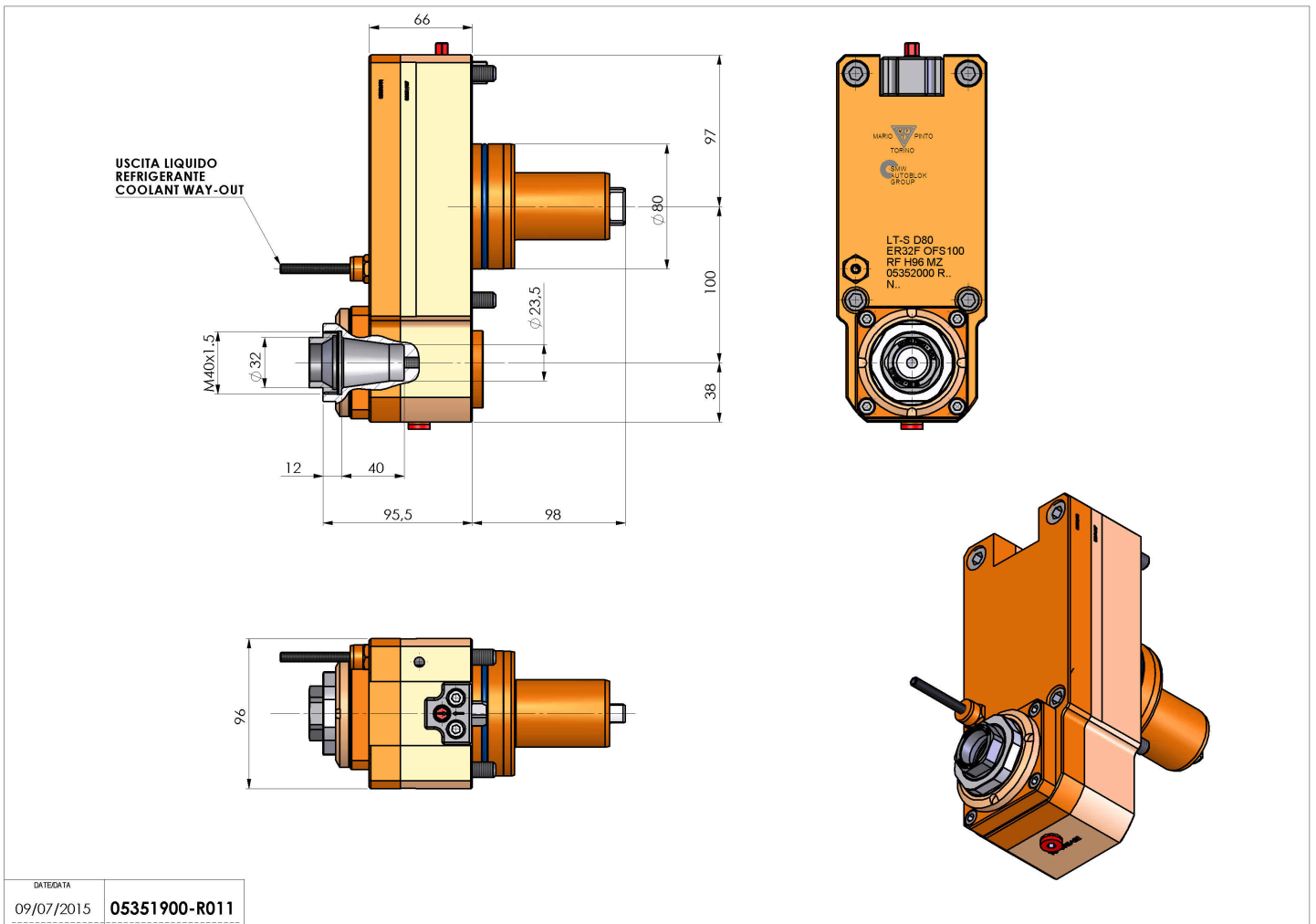

Subject to technical changes