

05351300 - LT-AD68ER25FRFOFS1:1.75H84.5MZ

Type	LT-A OFS Tool holder offset angle 90°
Mounting	CYLINDRICAL SHANK 68
Tool output	Collet nut ER 25 F - internal nut
Coolant	Internal coolant
Direction of rotation	r1 ↻ r2 ↻
Max speed [rpm]	in 5700 / out 10000
Max torque [Nm]	in 25 / out 14
Ratio	1:1,75
H [mm]	84,5
H1 [mm]	32,5
Max pressure [bar]	20
Accessories	N.A.
Notes	N.A.
Mounting tips	Main spindle only

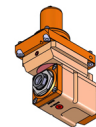

Always check live tool dimensions on the turret

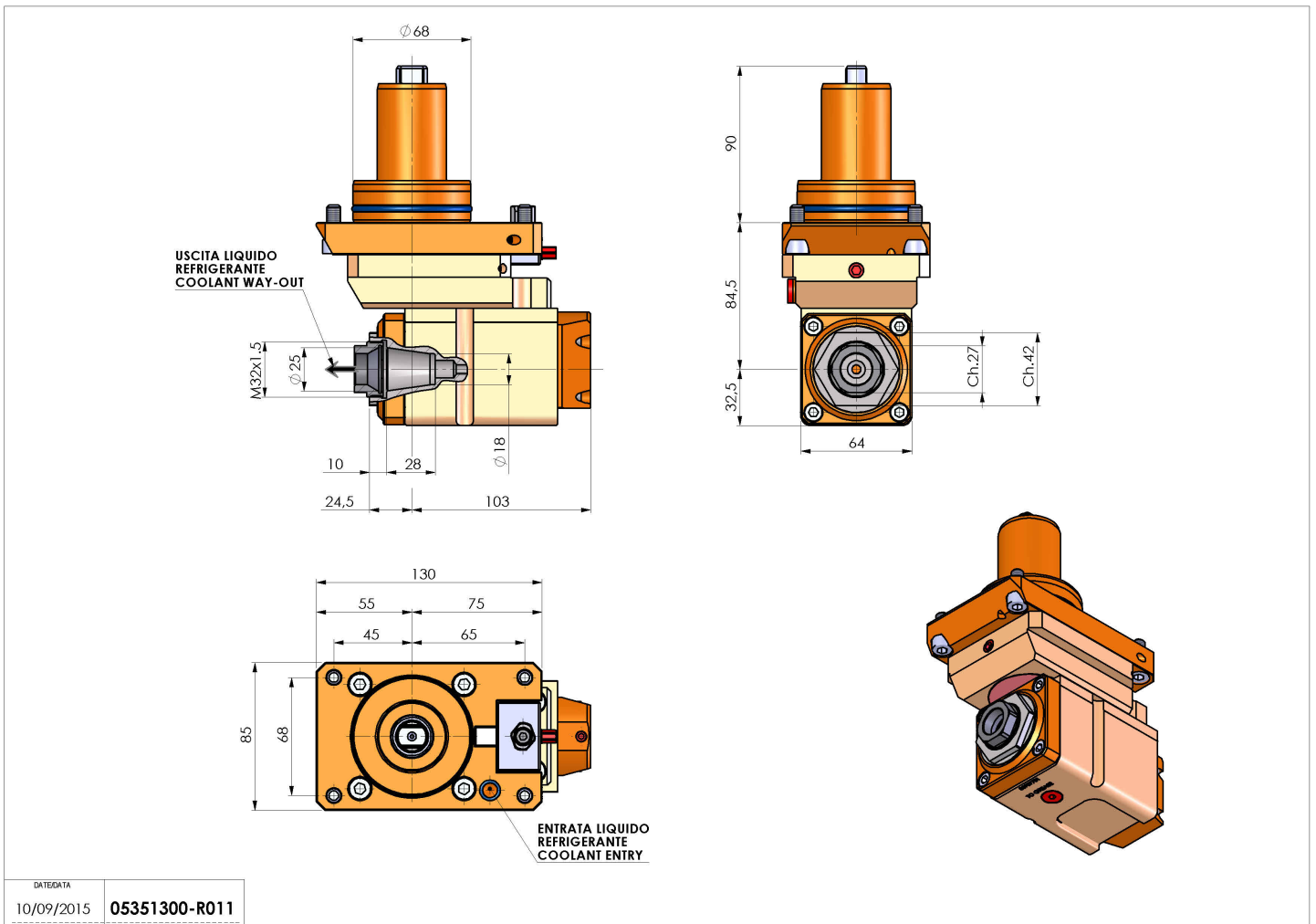

DATE/DATE	05351300-R011
10/09/2015	

Subject to technical changes