

05351200 - LT-A D68 DIN138-22 H80 MZ

| | |
|------------------------------|-------------------------------|
| Type | LT-A Tool holder angle 90° |
| Mounting | CYLINDRICAL SHANK 68 |
| Tool output | Shell-Mill DIN138 22 |
| Coolant | External coolant |
| Direction of rotation | r1 ↻ r2 ↻ |
| Max speed [rpm] | 6000 |
| Max torque [Nm] | 63 |
| Ratio | 1:1 |
| H [mm] | 80 |
| H1 [mm] | 38 |
| Accessories | N.A. |
| Notes | N.A. |
| Mounting tips | Main spindle only |

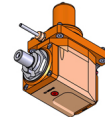

Always check live tool dimensions on the turret

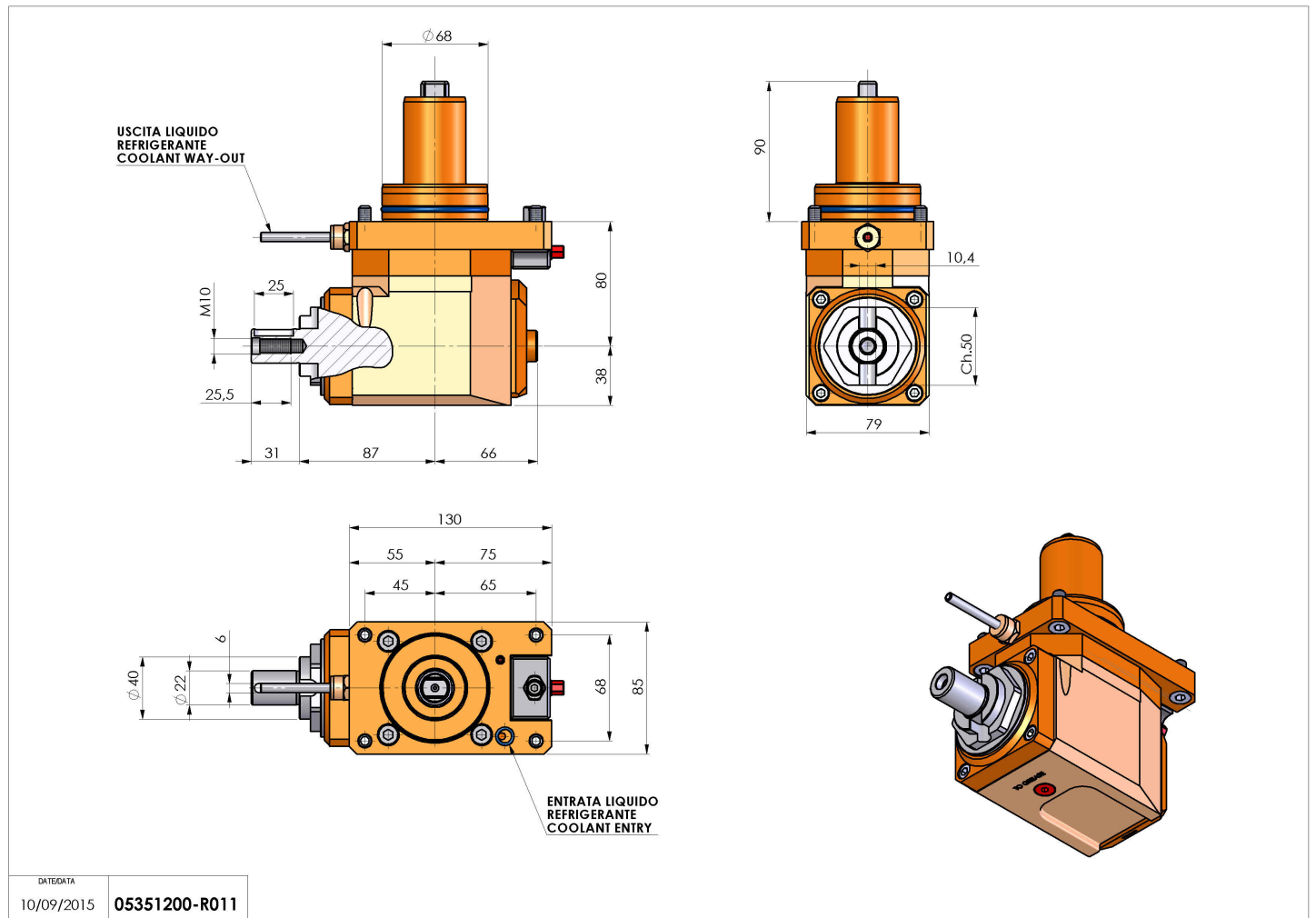

Subject to technical changes