



05350900 - LT-A D68 WELDON16 RF H80 MZ

Type	LT-A Tool holder angle 90°
Mounting	CYLINDRICAL SHANK 68
Tool output	Weldon 16 DIN1835B
Coolant	Internal coolant
Direction of rotation	r1  r2 
Max speed [rpm]	6000
Max torque [Nm]	63
Ratio	1:1
H [mm]	80
H1 [mm]	38
Max pressure [bar]	20
Accessories	N.A.
Notes	N.A.
Mounting tips	Main spindle only



Always check live tool dimensions on the turret

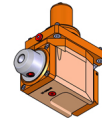
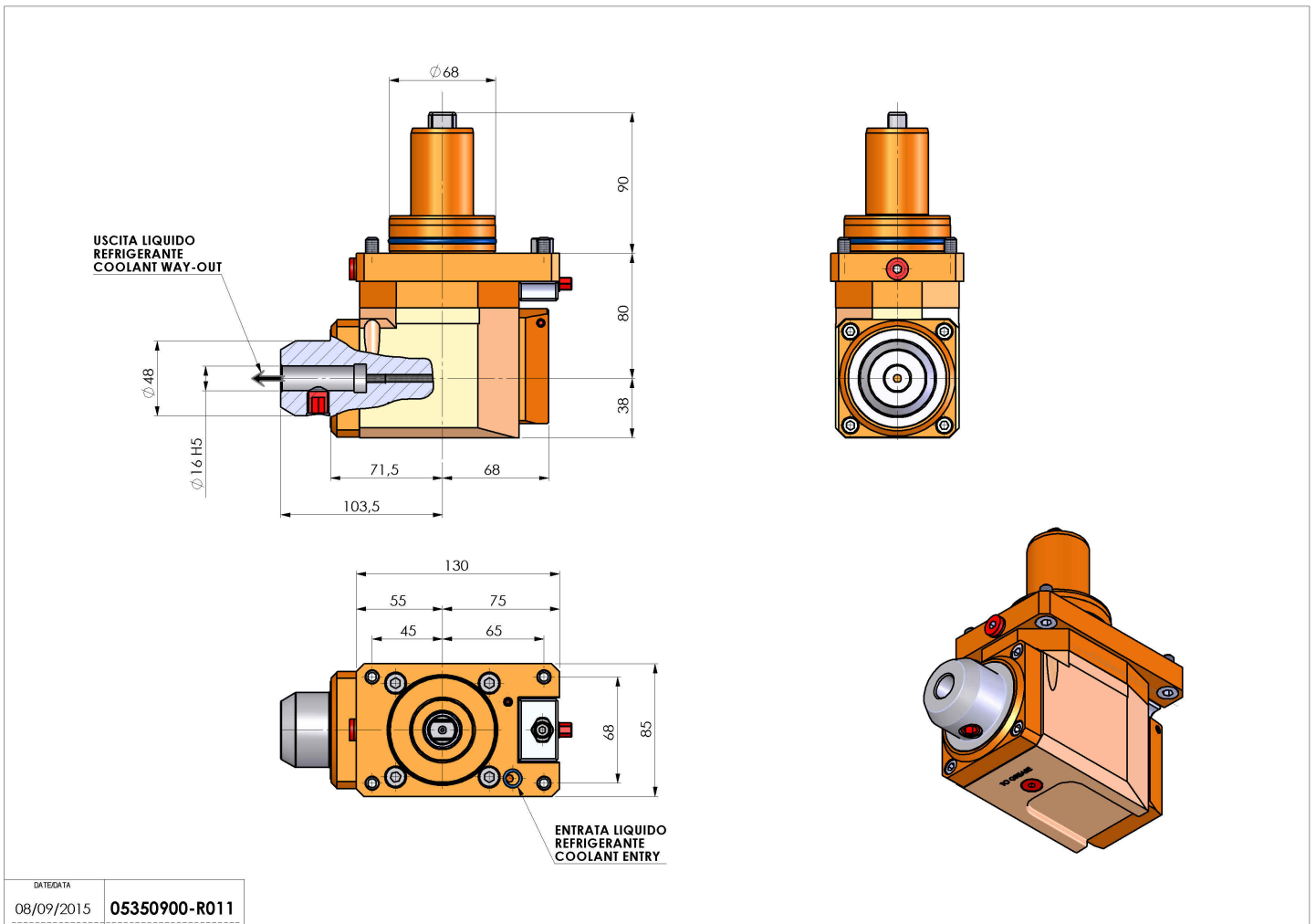

DATE/DATE	08/09/2015	05350900-R011
-----------	------------	---------------

Subject to technical changes