

# 05350400 - LT-AOFS1:1.75D68ER25FKRH84.5MZ

<b>Type</b>	LT-A OFS Tool holder offset angle 90°
<b>Mounting</b>	CYLINDRICAL SHANK 68
<b>Tool output</b>	Collet nut ER 25 F - internal nut
<b>Coolant</b>	External coolant
<b>Direction of rotation</b>	r1 ↻ r2 ↻
<b>Max speed [rpm]</b>	in 5700 / out 10000
<b>Max torque [Nm]</b>	in 25 / out 14
<b>Ratio</b>	1:1,75
<b>H [mm]</b>	84,5
<b>H1 [mm]</b>	32,5
<b>Accessories</b>	N.A.
<b>Notes</b>	N.A.
<b>Mounting tips</b>	Main spindle only

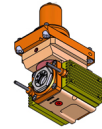

Always check live tool dimensions on the turret

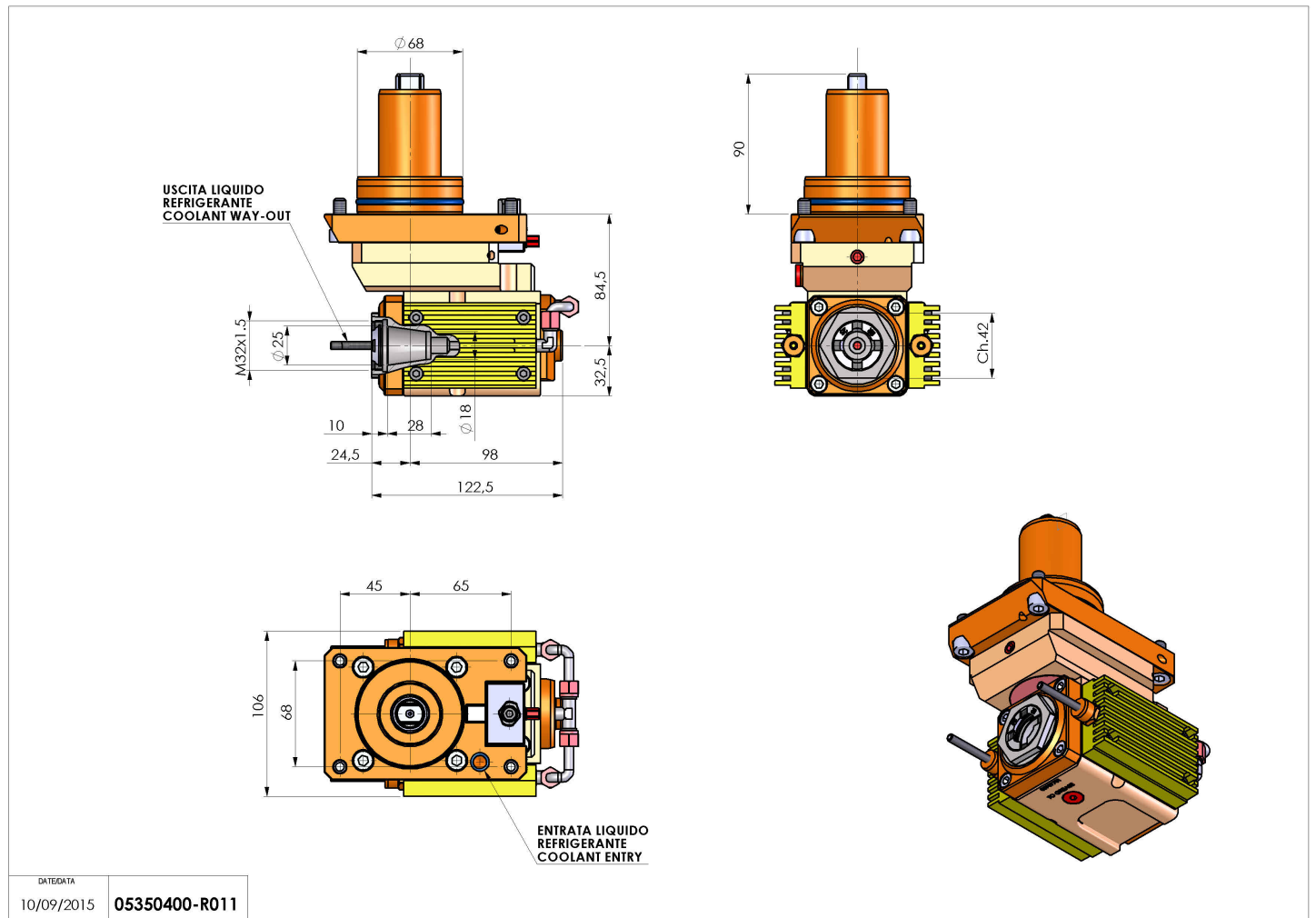

Subject to technical changes