



05350000 - LT-S D68 ER32F RF H63 MZ

Type	LT-S Tool holder straight
Mounting	CYLINDRICAL SHANK 68
Tool output	Collet nut ER 32 F - internal nut
Coolant	Internal coolant
Direction of rotation	r1  r2 
Max speed [rpm]	6000
Max torque [Nm]	63
Ratio	1:1
H [mm]	63
Max pressure [bar]	20
Accessories	
Notes	N.A.
Mounting tips	N.A.



Always check live tool dimensions on the turret

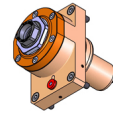
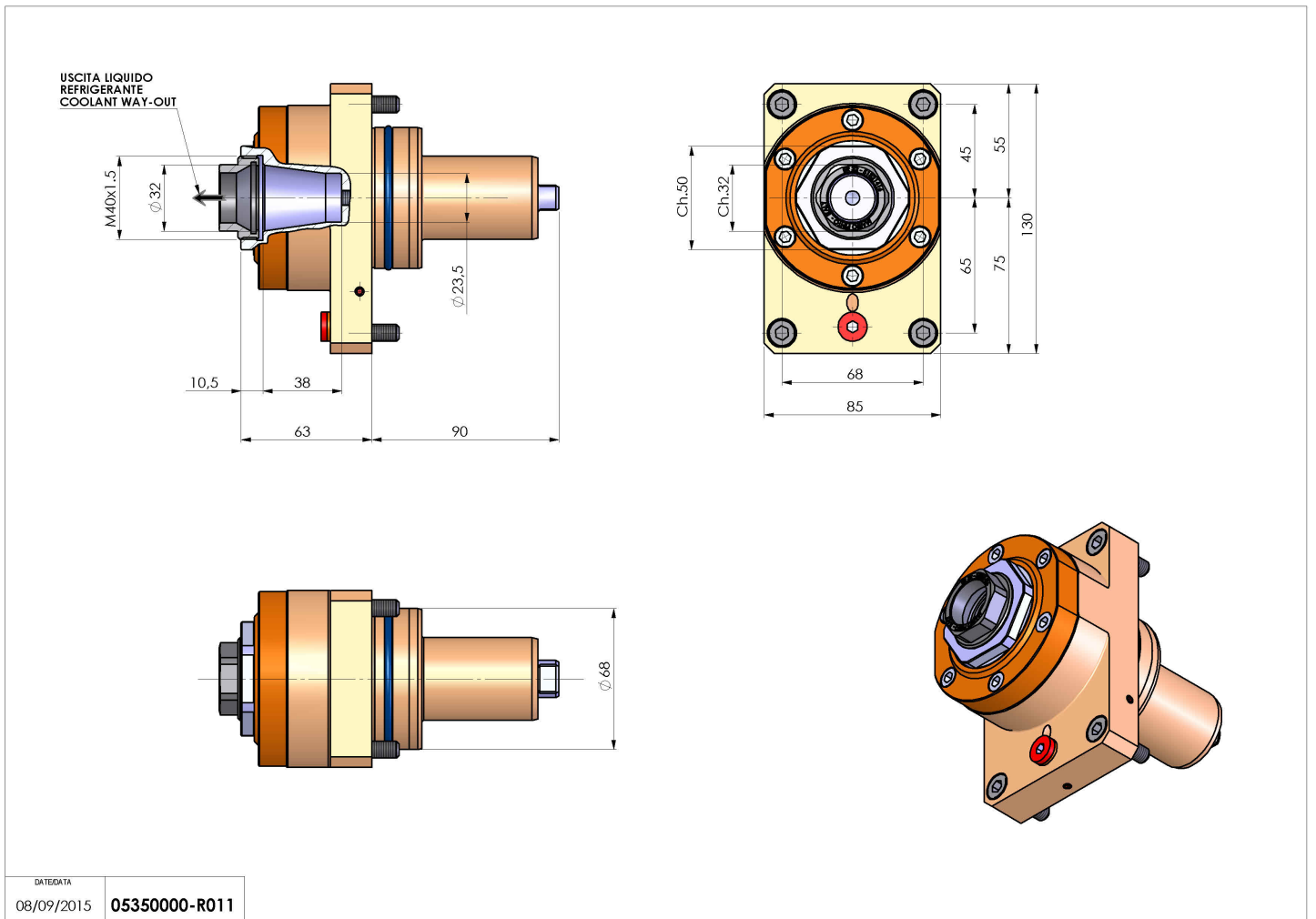

Subject to technical changes