

# 05338500 - LT-A BMT45 ER25 OFS 1:2 LR H85

<b>Type</b>	LT-A OFS Tool holder offset angle 90°
<b>Mounting</b>	BMT 45
<b>Tool output</b>	Collet nut ER 25
<b>Coolant</b>	External coolant
<b>Direction of rotation</b>	r1  r2
<b>Max speed [rpm]</b>	in 6000 /out 12000
<b>Max torque [Nm]</b>	in 25 / out 12.5
<b>Ratio</b>	1:2
<b>H [mm]</b>	85
<b>H1 [mm]</b>	32.5
<b>Accessories</b>	N.A.
<b>Notes</b>	N.A.
<b>Mounting tips</b>	Main and secondary spindle

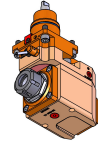

Always check live tool dimensions on the turret

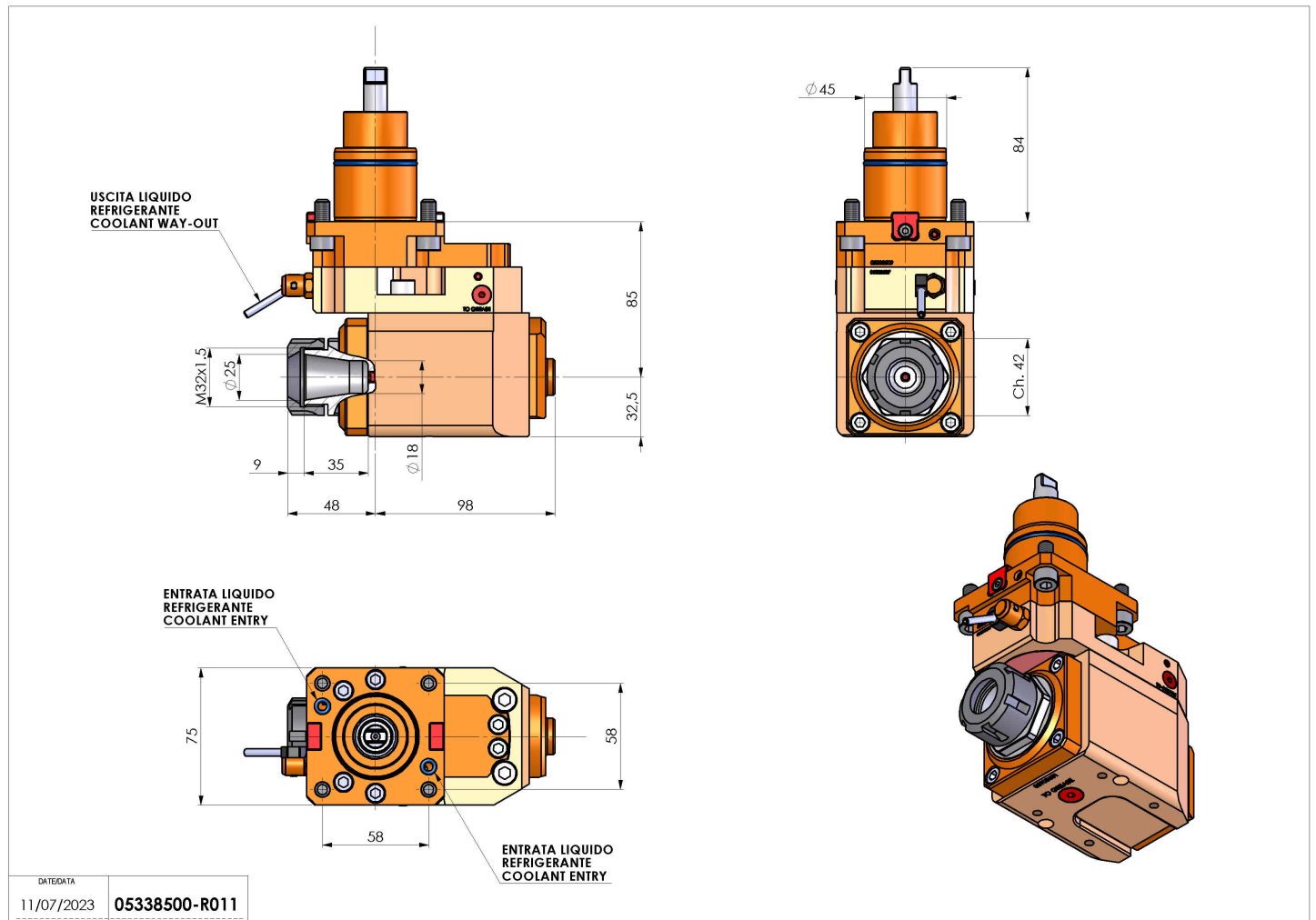

DATE/DATA	11/07/2023
PART NUMBER	05338500-R011

Subject to technical changes