

05330700 - LT-A BMT75 ER40 LR RF H90

Type	LT-A Tool holder angle 90°
Mounting	BMT 75
Tool output	Collet nut ER 40
Coolant	Internal coolant
Direction of rotation	r1 ↻ r2 ↻
Max speed [rpm]	4000
Max torque [Nm]	80
Ratio	1:1
H [mm]	90
H1 [mm]	43
Max pressure [bar]	20
Accessories	N.A.
Notes	N.A.
Mounting tips	N.A.

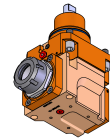

Always check live tool dimensions on the turret

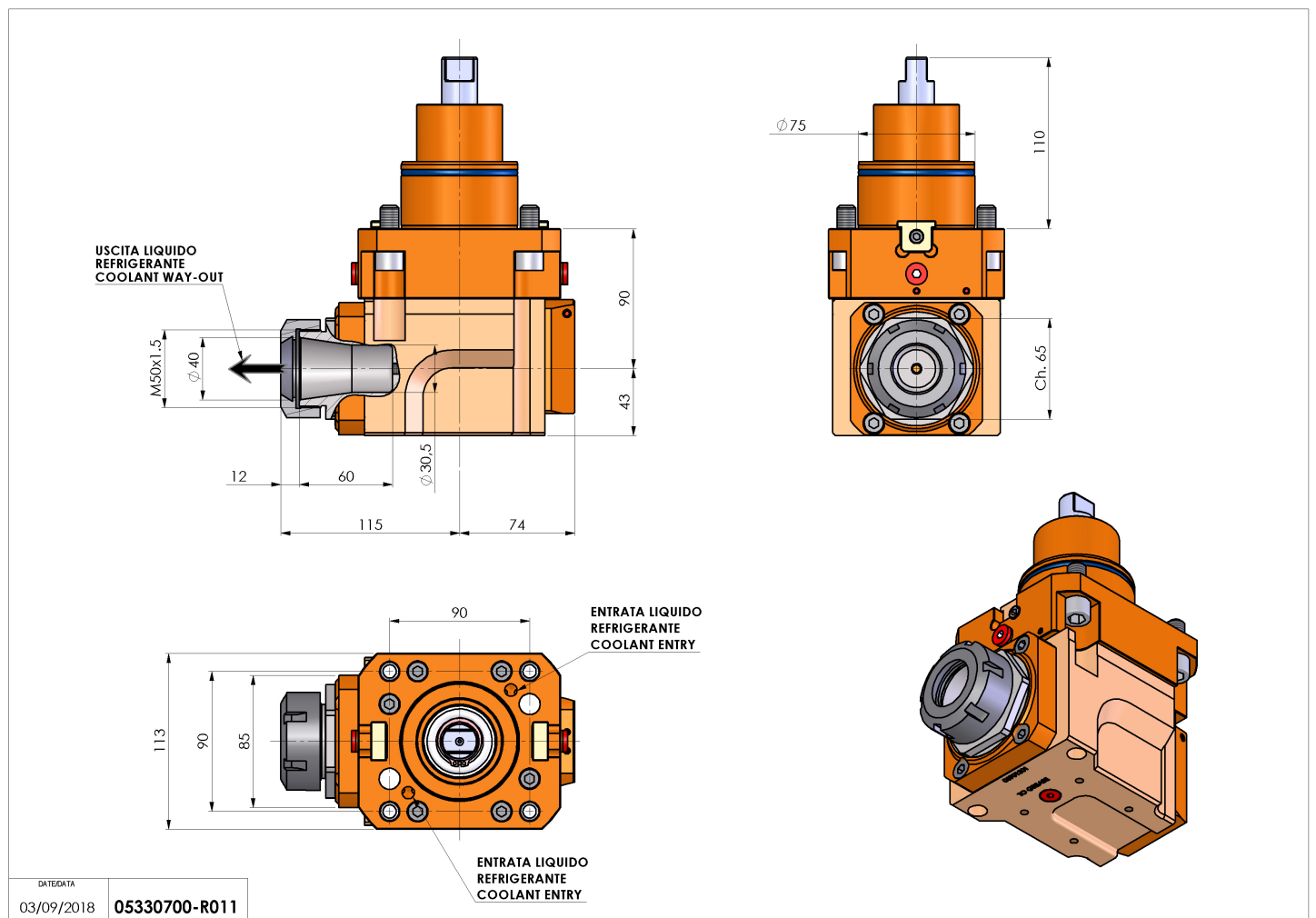

Subject to technical changes