

05320400 - LT-A BMT75 ER32F RF OF LR1:2 H90

Type	LT-A OFS Tool holder offset angle 90°
Mounting	BMT 75
Tool output	Collet nut ER 32 F - internal nut
Coolant	Internal coolant
Direction of rotation	r1 ↻ r2 ↻
Max speed [rpm]	in 4000 / out 8000
Max torque [Nm]	in 50 / out 25
Ratio	1:2
H [mm]	90
H1 [mm]	38
Max pressure [bar]	20
Accessories	N.A.
Notes	N.A.
Mounting tips	N.A.

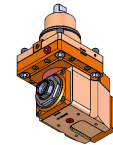

Always check live tool dimensions on the turret

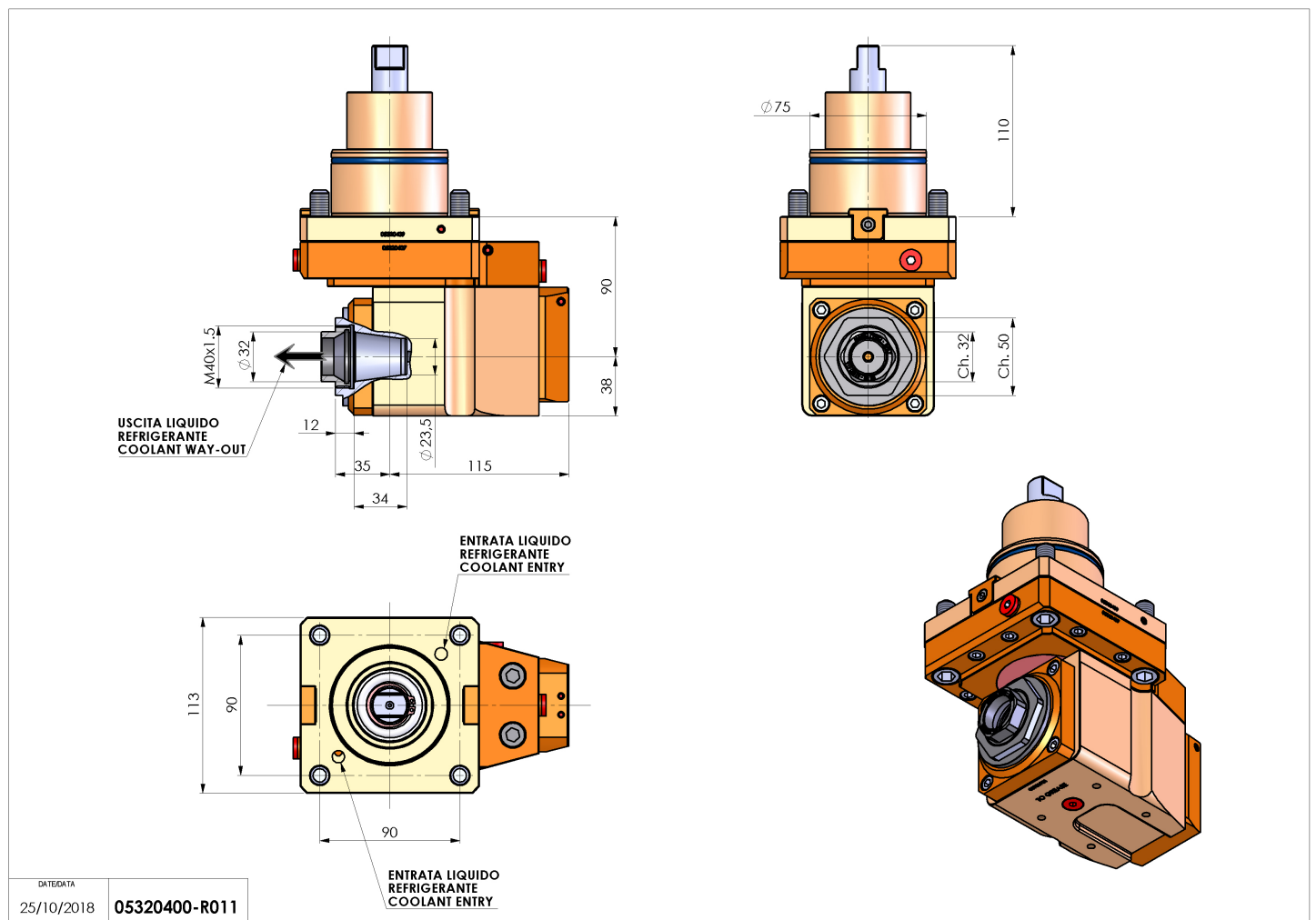

DATE/DATE	05320400-R011
25/10/2018	

Subject to technical changes