



## 05320200 - LT-S BMT75 ER32F OF51RF1:2H110

<b>Type</b>	LT-S OFS Tool holder straight offset
<b>Mounting</b>	BMT 75
<b>Tool output</b>	Collet nut ER 32 F - internal nut
<b>Coolant</b>	Internal coolant
<b>Offset [mm]</b>	51
<b>Direction of rotation</b>	r1  r2 
<b>Max speed [rpm]</b>	in 4000 / out 8000
<b>Max torque [Nm]</b>	in 50 / out 25
<b>Ratio</b>	1:2
<b>H [mm]</b>	110
<b>Max pressure [bar]</b>	20
<b>Accessories</b>	N.A.
<b>Notes</b>	N.A.
<b>Mounting tips</b>	N.A.



Always check live tool dimensions on the turret

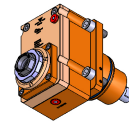
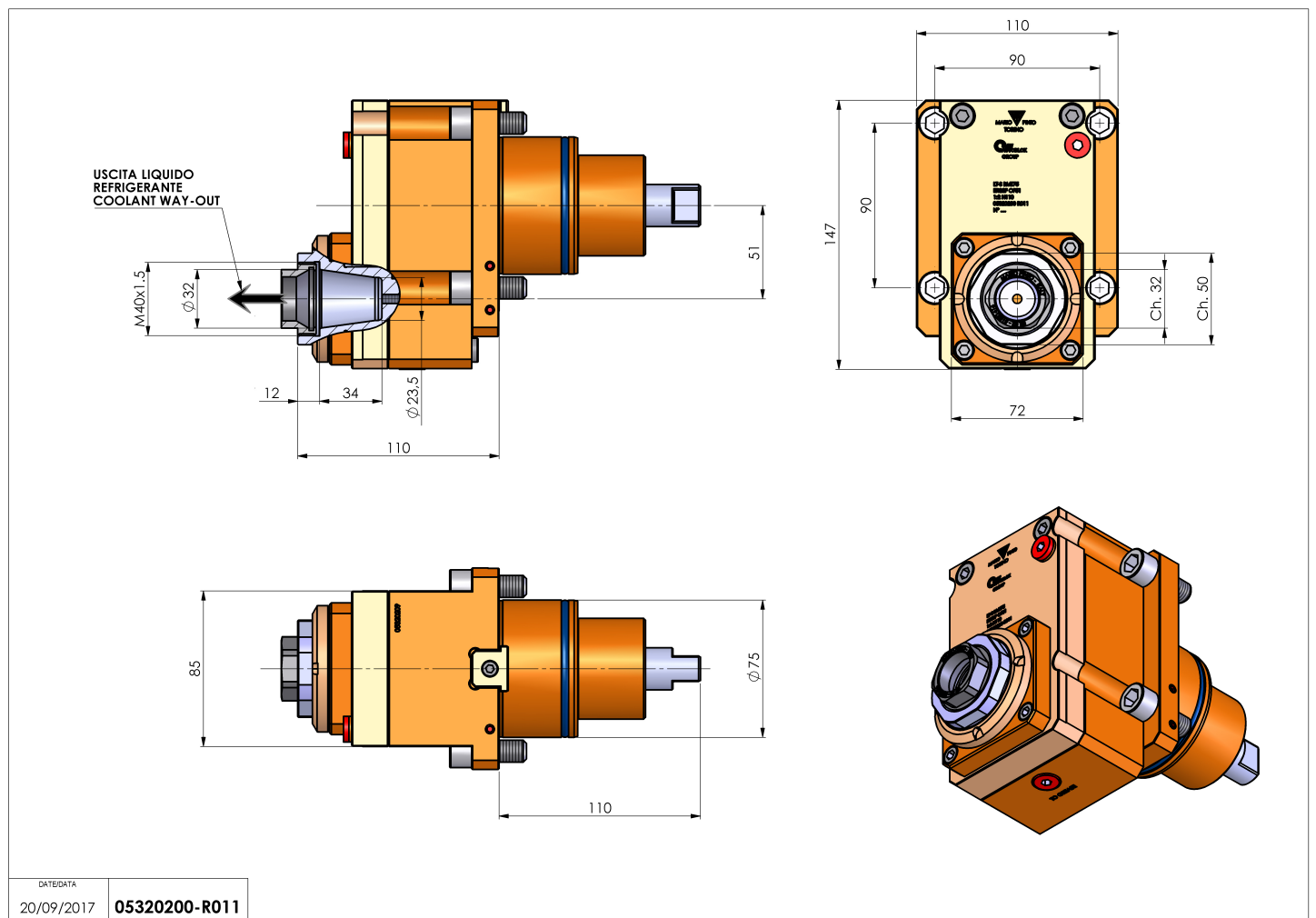

DATE/DATA  
20/09/2017 05320200-R011

Subject to technical changes