



05320100 - LT-S BMT75 HSK63 RF H82.5

Type	LT-S Tool holder straight
Mounting	BMT 75
Tool output	Quick Change HSK63
Coolant	Internal coolant
Direction of rotation	r1  r2 
Max speed [rpm]	4000
Max torque [Nm]	100
Ratio	1:1
H [mm]	82,5
Max pressure [bar]	20
Accessories	N.A.
Notes	N.A.
Mounting tips	N.A.



Always check live tool dimensions on the turret

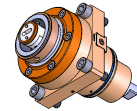
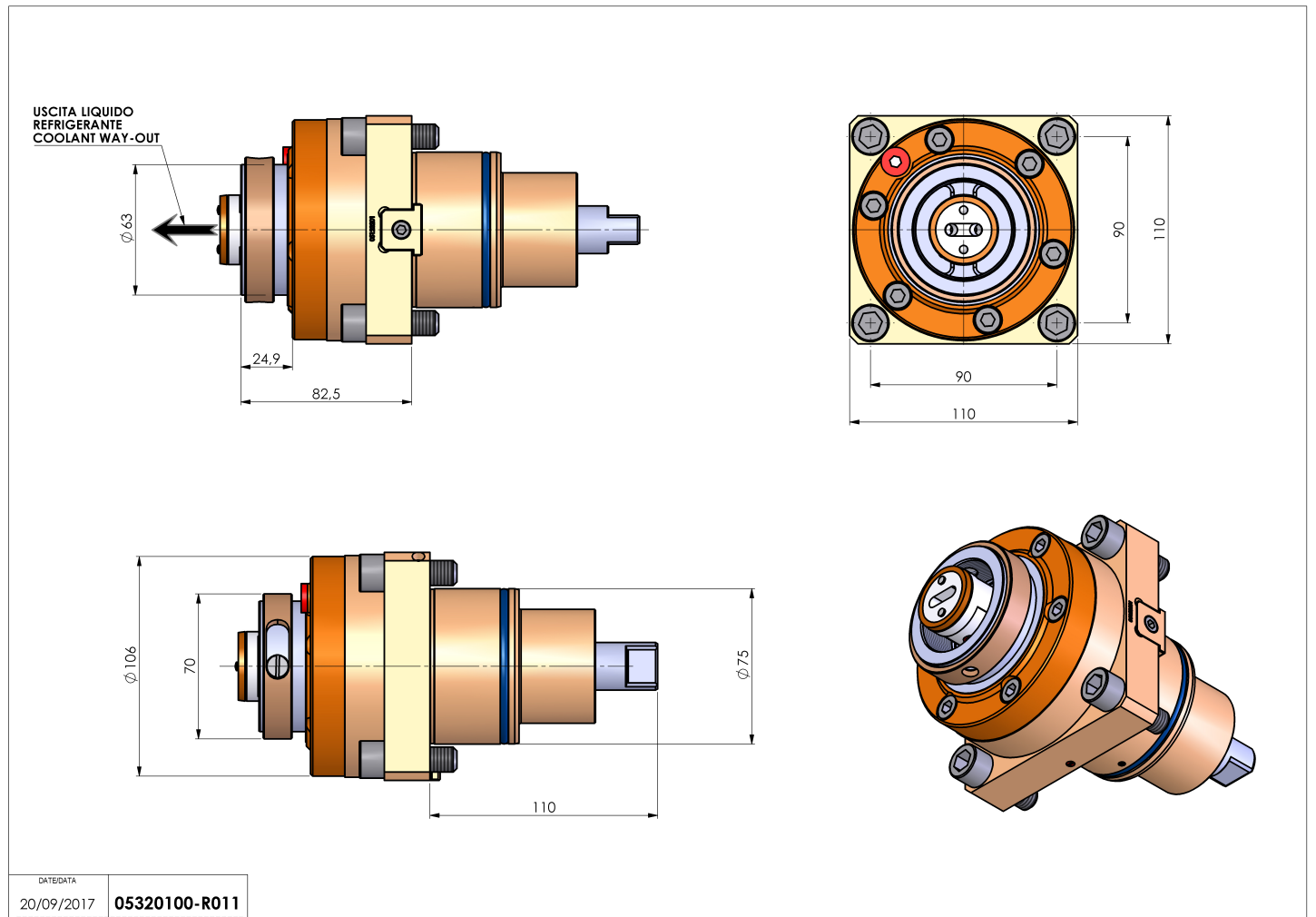

Subject to technical changes