

# 05319700 - LT-A BMT55 BD DIN138-22 LR H70

<b>Type</b>	LT-A Tool holder angle 90°
<b>Mounting</b>	BMT 55 BIG DRIVE
<b>Tool output</b>	Shell-Mill DIN138 22
<b>Coolant</b>	External coolant
<b>Direction of rotation</b>	r1  r2
<b>Max speed [rpm]</b>	6000
<b>Max torque [Nm]</b>	40
<b>Ratio</b>	1:1
<b>H [mm]</b>	70
<b>H1 [mm]</b>	32.5
<b>Accessories</b>	N.A.
<b>Notes</b>	N.A.
<b>Mounting tips</b>	Main and secondary spindle

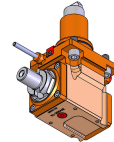

Always check live tool dimensions on the turret

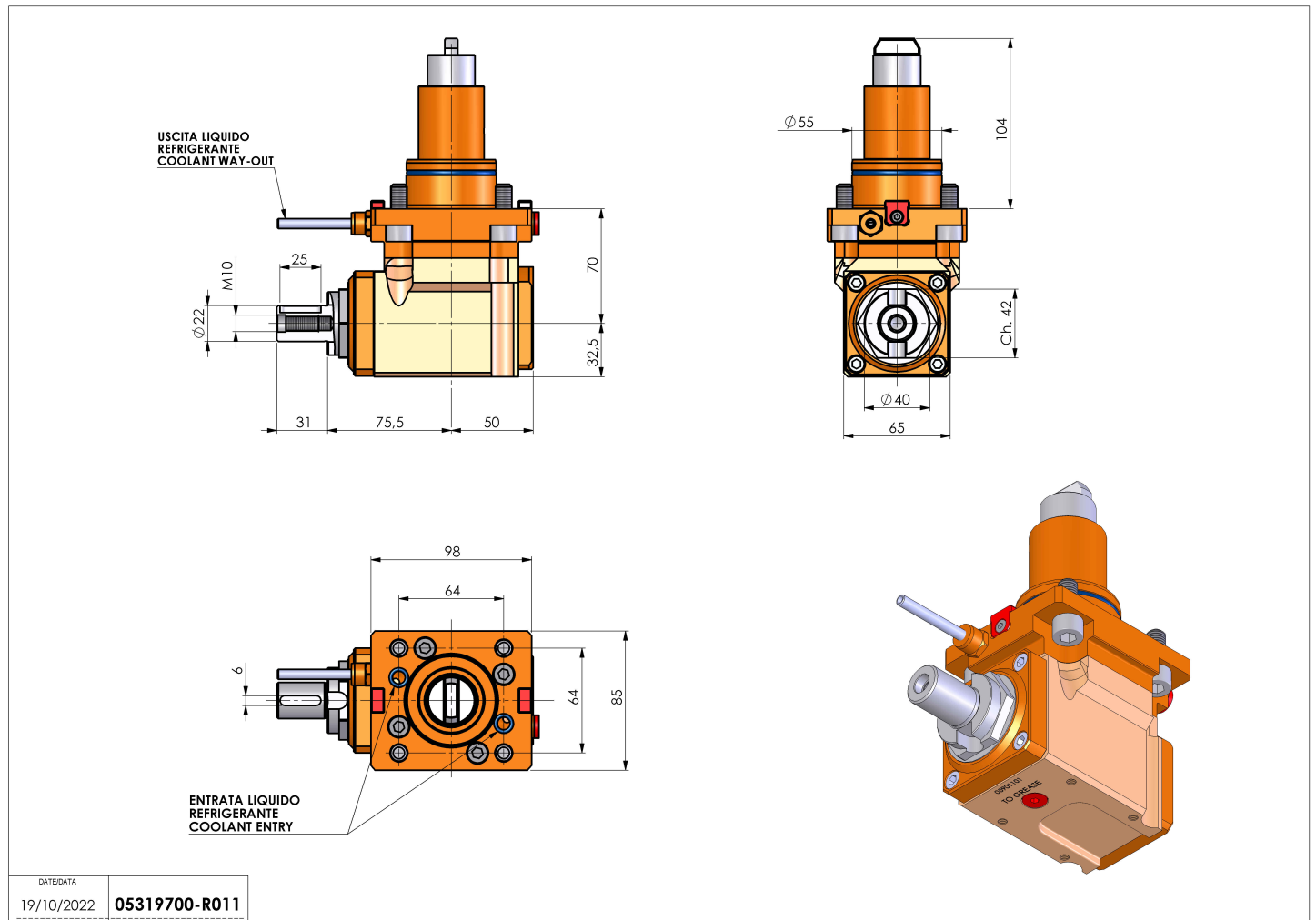

DATE/DATA	19/10/2022	05319700-R011
-----------	------------	---------------

Subject to technical changes