

## 05318200 - LT-A BMT55 BD DIN138-22 LR 2:1 H85

<b>Type</b>	LT-A Tool holder angle 90°
<b>Mounting</b>	BMT 55 BIG DRIVE
<b>Tool output</b>	Shell-Mill DIN138 22
<b>Coolant</b>	External coolant
<b>Direction of rotation</b>	r1 ↻ r2 ↻
<b>Max speed [rpm]</b>	in 6000 / out 3000
<b>Max torque [Nm]</b>	in 70 / out 140
<b>Ratio</b>	2:1
<b>H [mm]</b>	85
<b>H1 [mm]</b>	38
<b>Accessories</b>	N.A.
<b>Notes</b>	N.A.
<b>Mounting tips</b>	N.A.

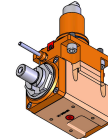

Always check live tool dimensions on the turret

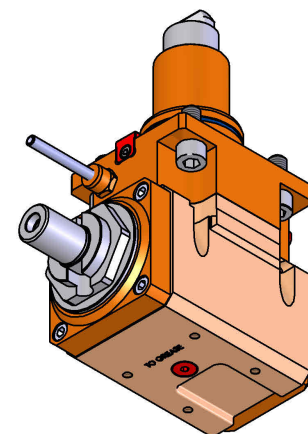
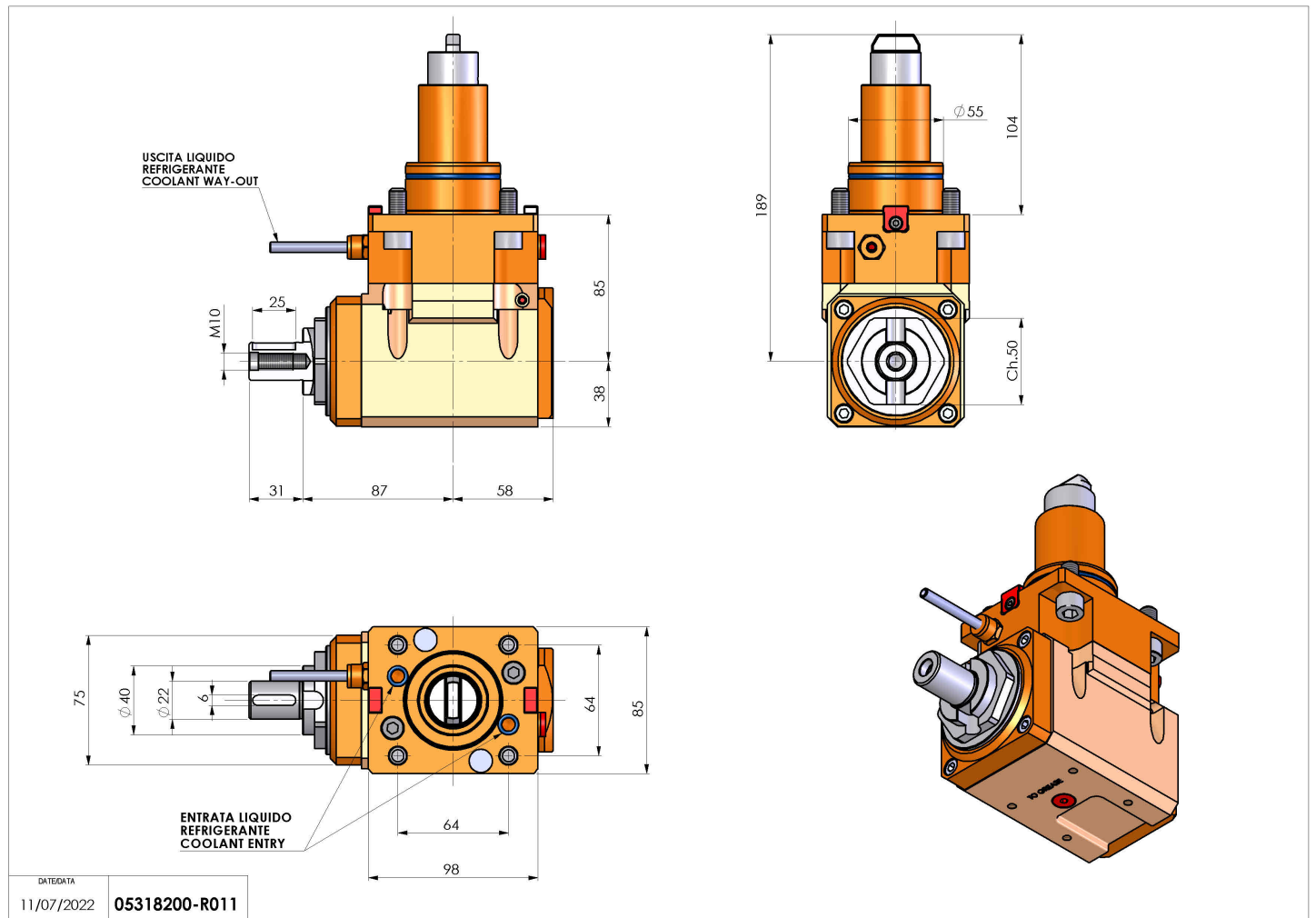

Subject to technical changes