



## 05315700 - LT-A BMT75 BD ER40 LR H90

<b>Type</b>	LT-A Tool holder angle 90°
<b>Mounting</b>	BMT 75 BIG DRIVE
<b>Tool output</b>	Collet nut ER 40
<b>Coolant</b>	HRF Internal coolant
<b>Direction of rotation</b>	r1  r2 
<b>Max speed [rpm]</b>	4000
<b>Max torque [Nm]</b>	80
<b>Ratio</b>	1:1
<b>H [mm]</b>	90
<b>H1 [mm]</b>	43
<b>Max pressure [bar]</b>	80
<b>Accessories</b>	N.A.
<b>Notes</b>	N.A.
<b>Mounting tips</b>	Main and secondary spindle



Always check live tool dimensions on the turret

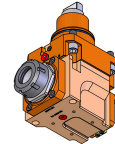
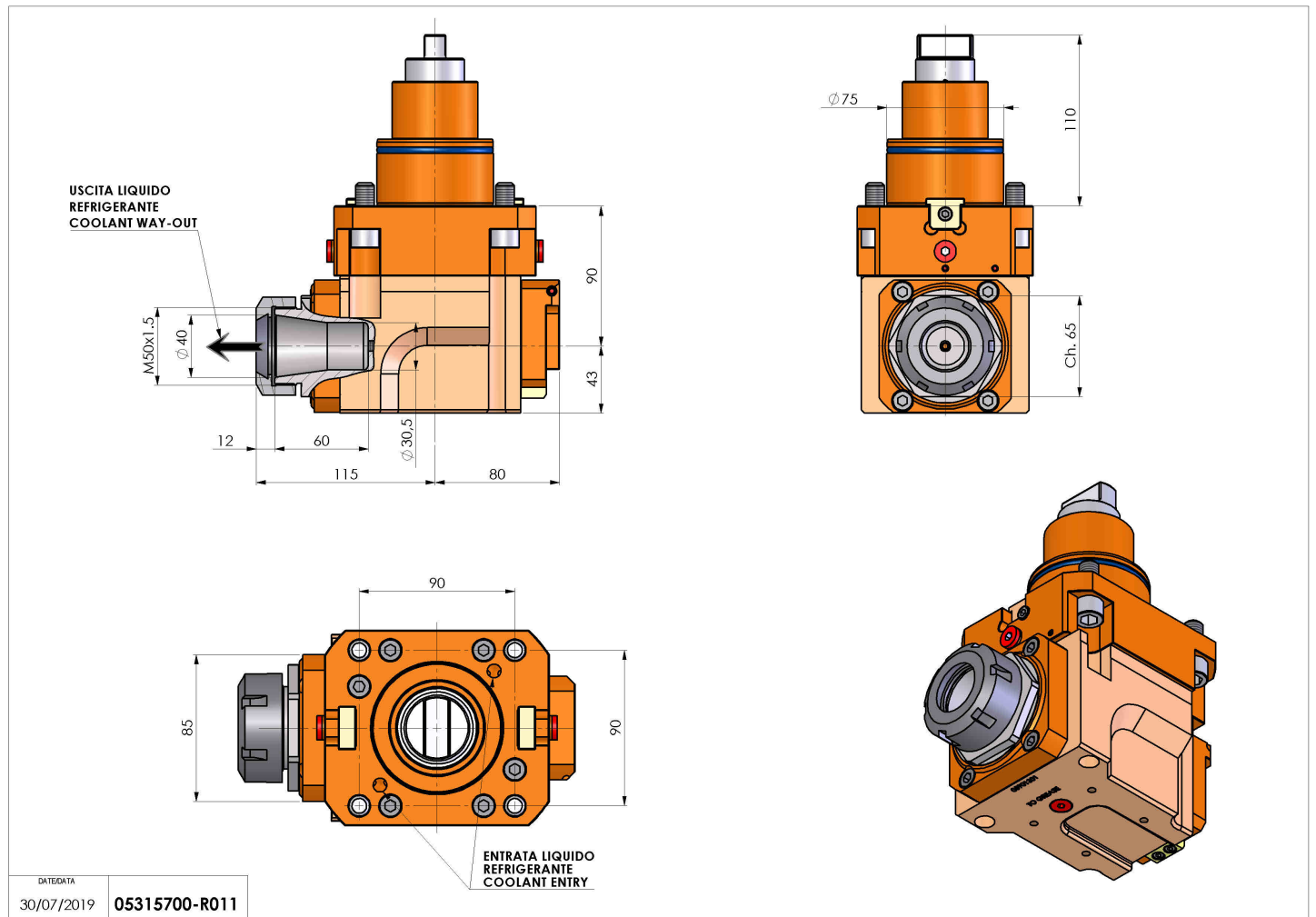

Subject to technical changes