



## 05313600 - LT-T BMT65 BD ER20F H71-149

<b>Type</b>	LT-T Tool holder tiltable
<b>Mounting</b>	BMT 65 BIG DRIVE
<b>Tool output</b>	Collet nut ER 20 F - internal nut
<b>Coolant</b>	External coolant
<b>Direction of rotation</b>	r1  r2 
<b>Max speed [rpm]</b>	6000
<b>Max torque [Nm]</b>	20
<b>Ratio</b>	1:1
<b>H [mm]</b>	71-149
<b>Accessories</b>	N.A.
<b>Notes</b>	N.A.
<b>Mounting tips</b>	N.A.



Always check live tool dimensions on the turret

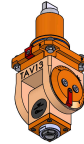
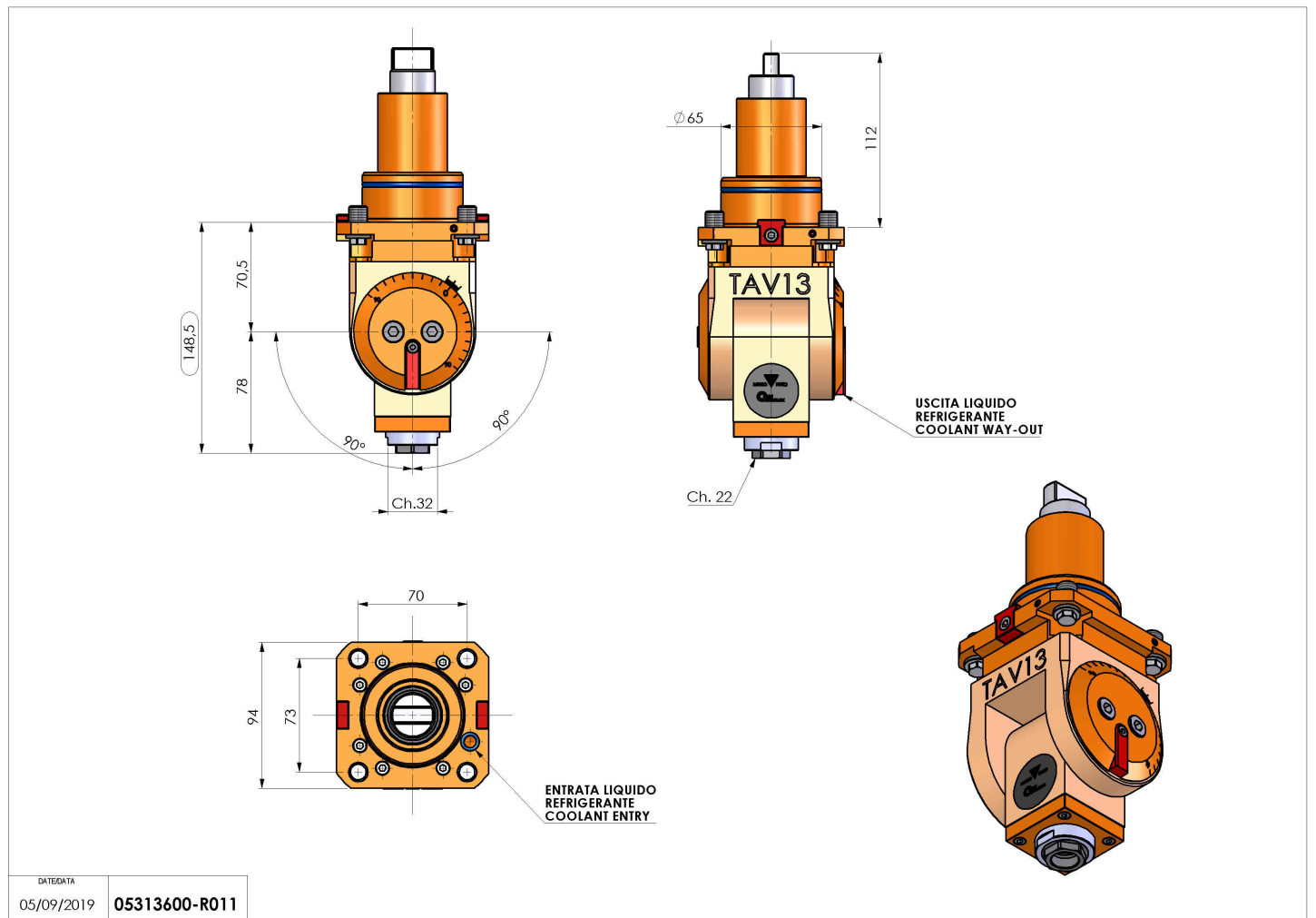

DATE/DATE  
05/09/2019 05313600-R011

Subject to technical changes