

05300700 - LT-A BMT45 ER25 OFS 1:1 H100

Type	LT-A OFS Tool holder offset angle 90°
Mounting	BMT 45
Tool output	Collet nut ER 25
Coolant	External coolant
Direction of rotation	r1 r2
Max speed [rpm]	6000
Max torque [Nm]	25
Ratio	1:1
H [mm]	100
H1 [mm]	32.5
Accessories	N.A.
Notes	N.A.
Mounting tips	Main and secondary spindle

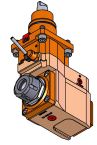

Always check live tool dimensions on the turret

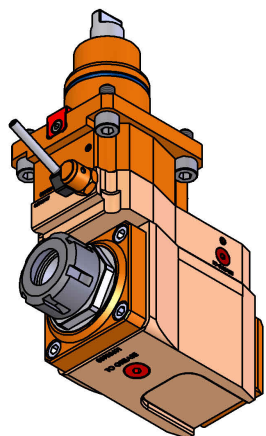
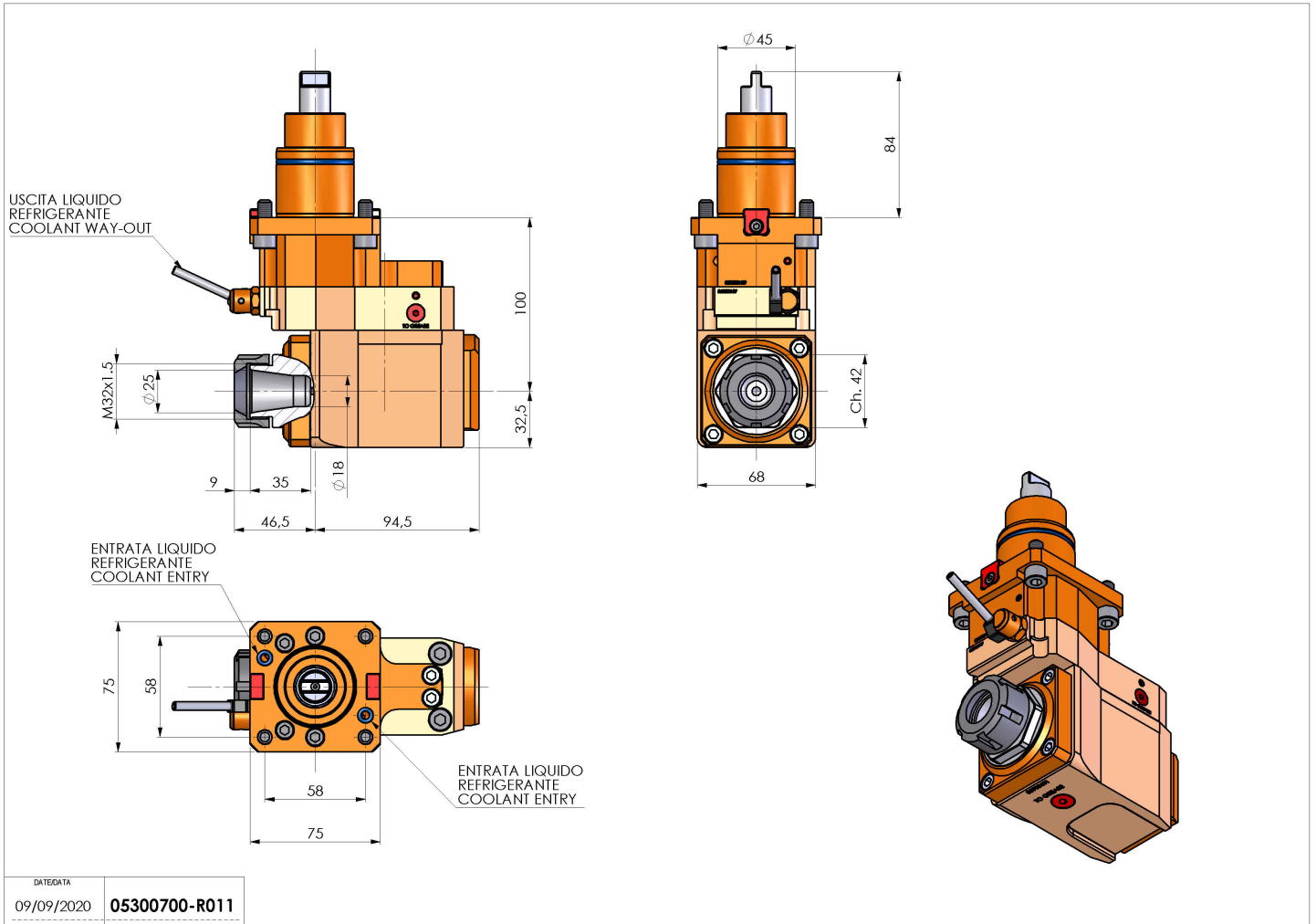

Subject to technical changes