

05290900 - LT-A D32 ER25F-ER25F HS H60

Type	LT-A DBL Tool holder double angle 90°
Mounting	CYLINDRICAL SHANK 32
Tool output	Collet nut ER 25 F - internal nut
Coolant	External coolant
Direction of rotation	r1 ↻ r2 ↻
Max speed [rpm]	12000
Max torque [Nm]	70
Ratio	1:1
H [mm]	60
H1 [mm]	40
Accessories	N.A.
Notes	N.A.
Mounting tips	N.A.

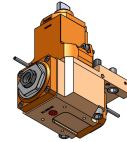

Always check live tool dimensions on the turret

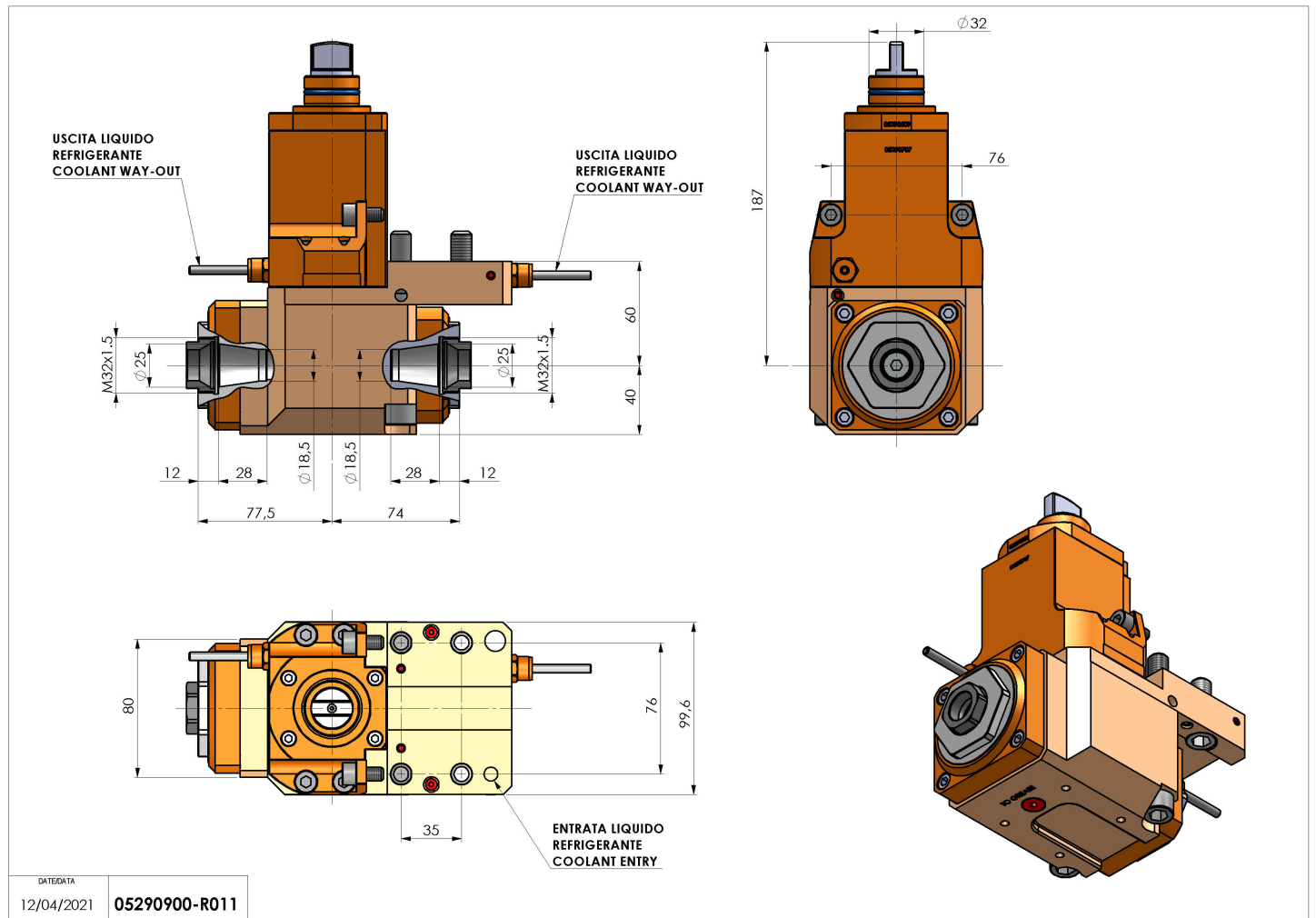

DATE/DATE
12/04/2021 05290900-R011

Subject to technical changes