

05290700 - LT-A D32 ER32-32 HS H60

Type	LT-A DBL Tool holder double angle 90°
Mounting	CYLINDRICAL SHANK 32
Tool output	Collet nut ER 32
Coolant	External coolant
Direction of rotation	r1 ↻ r2 ↻
Max speed [rpm]	12000
Max torque [Nm]	70
Ratio	1:1
H [mm]	60
H1 [mm]	40
Accessories	N.A.
Notes	N.A.
Mounting tips	N.A.

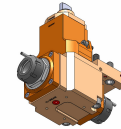

Always check live tool dimensions on the turret

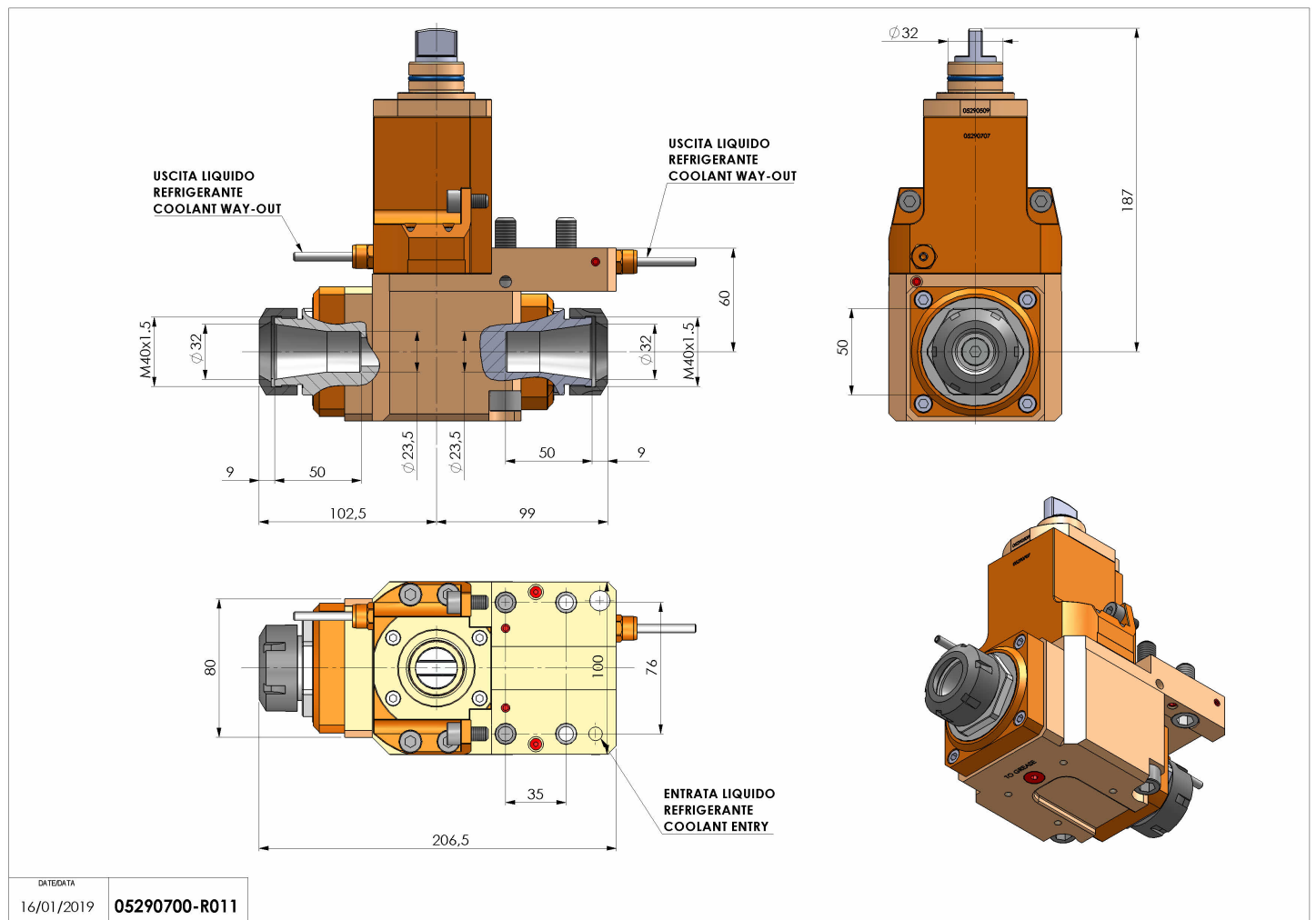

DATE/DATE	05290700-R011
16/01/2019	

Subject to technical changes