

05282800 - LT-A D54 ER32F HRF 2:1 H75 MY

Type	LT-A Tool holder angle 90°
Mounting	CYLINDRICAL SHANK 54
Tool output	Collet nut ER 32 F - internal nut
Coolant	HRF Internal coolant
Direction of rotation	r1 ↻ r2 ↻
Max speed [rpm]	in 6000 / out 3000
Max torque [Nm]	in 40 / out 80
Ratio	2:1
H [mm]	75
H1 [mm]	38
Max pressure [bar]	80
Accessories	N.A.
Notes	N.A.
Mounting tips	N.A.

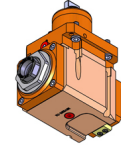

Always check live tool dimensions on the turret

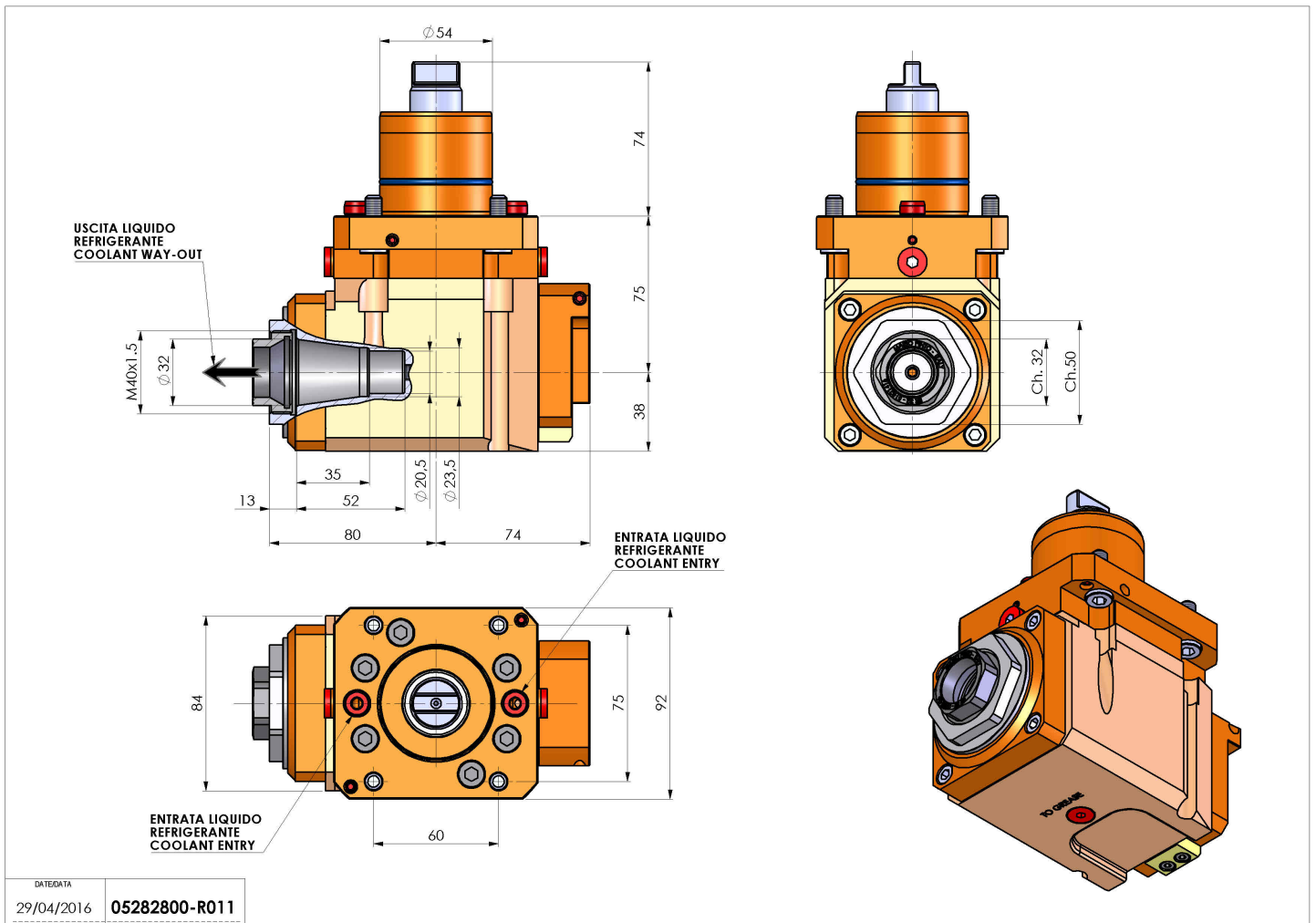

DATE/DATE	05282800-R011
29/04/2016	

Subject to technical changes