

05281700 - LT-A D54 ER32 H75 MY

Type	LT-A Tool holder angle 90°
Mounting	CYLINDRICAL SHANK 54
Tool output	Collet nut ER 32
Coolant	External coolant
Direction of rotation	r1 r2
Max speed [rpm]	6000
Max torque [Nm]	40
Ratio	1:1
H [mm]	75
H1 [mm]	36
Accessories	N.A.
Notes	N.A.
Mounting tips	N.A.

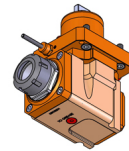

Always check live tool dimensions on the turret

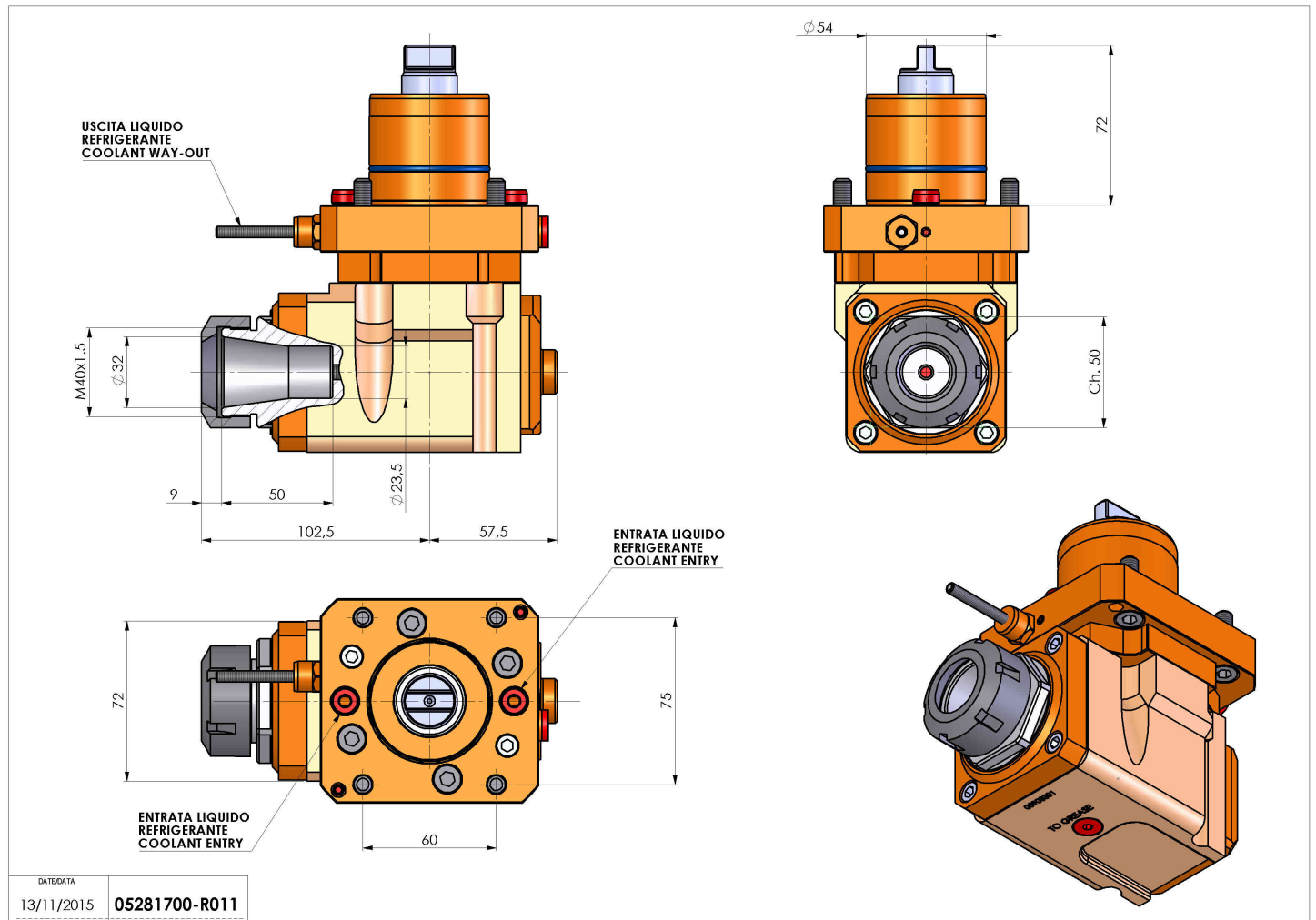

DATE/DATE	
13/11/2015	05281700-R011

Subject to technical changes