

05281500 - LT-S D54 ER32F RF H64 MY

Type	LT-S Tool holder straight
Mounting	CYLINDRICAL SHANK 54
Tool output	Collet nut ER 32 F - internal nut
Coolant	Internal coolant
Direction of rotation	r1 r2
Max speed [rpm]	6000
Max torque [Nm]	40
Ratio	1:1
H [mm]	64
Max pressure [bar]	20
Accessories	
Notes	N.A.
Mounting tips	N.A.

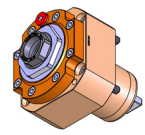

Always check live tool dimensions on the turret

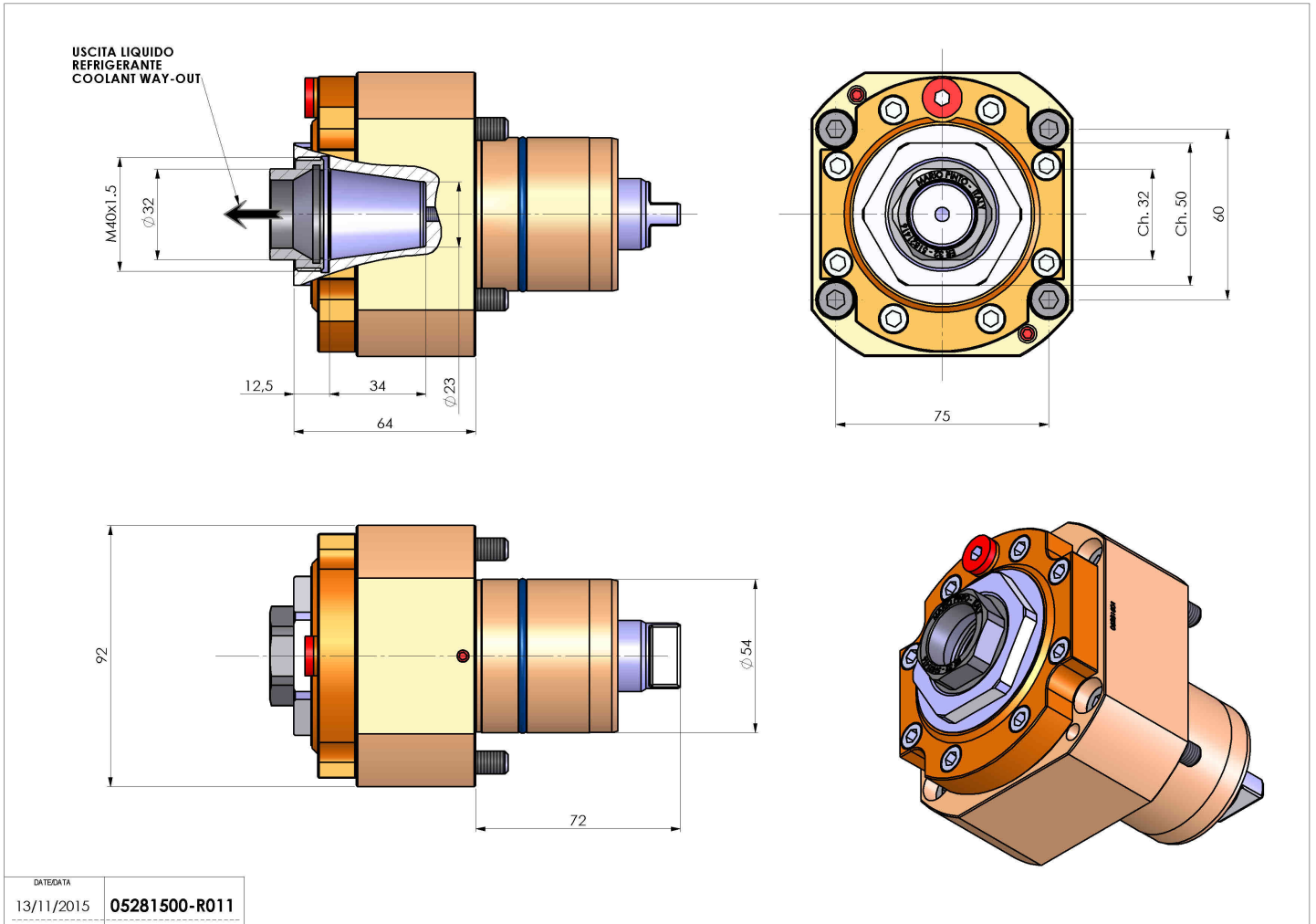

Subject to technical changes