

05264400 - LT-A D60 ER25F LR HRF 1:2 H70

Type	LT-A Tool holder angle 90°
Mounting	CYLINDRICAL SHANK 60
Tool output	Collet nut ER 25 F - internal nut
Coolant	HRF Internal coolant
Direction of rotation	r1 ↻ r2 ↻
Max speed [rpm]	in 6000 / out 12000
Max torque [Nm]	in 10 / out 5
Ratio	1:2
H [mm]	70
H1 [mm]	32.5
Max pressure [bar]	80
Accessories	N.A.
Notes	N.A.
Mounting tips	Main and secondary spindle

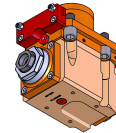

Always check live tool dimensions on the turret

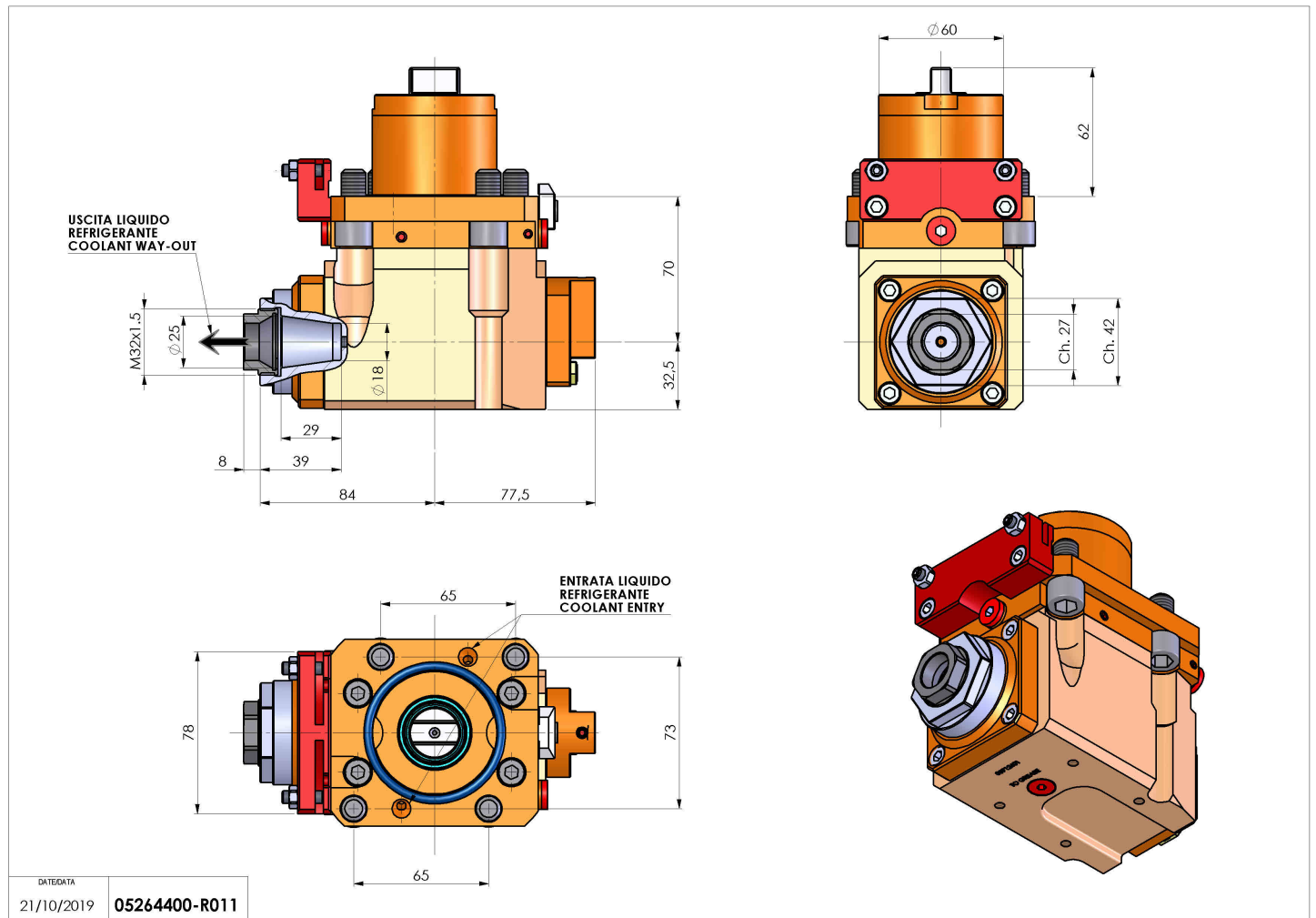

DATE/DATA
21/10/2019 05264400-R011

Subject to technical changes