

05260100 - LT-A ST35 VDI40 C12 H100 OK

Type	LT-A ST Slotting tool 90°
Mounting	VDI 40
Tool output	Tool diameter 12
Coolant	External coolant
Max speed [rpm]	700
Max torque [Nm]	17,5
Ratio	1:1
Y axis adjustment	NO
Feed pushing [N]	1000
Stroke [mm]	35
Work stroke [mm]	30
H [mm]	100
Accessories	N.A.
Notes	N.A.
Mounting tips	N.A.

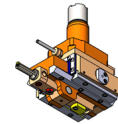

ATTENTION: CHECK THE ORIENTATION OF THE VDI TEETH

Always check live tool dimensions on the turret

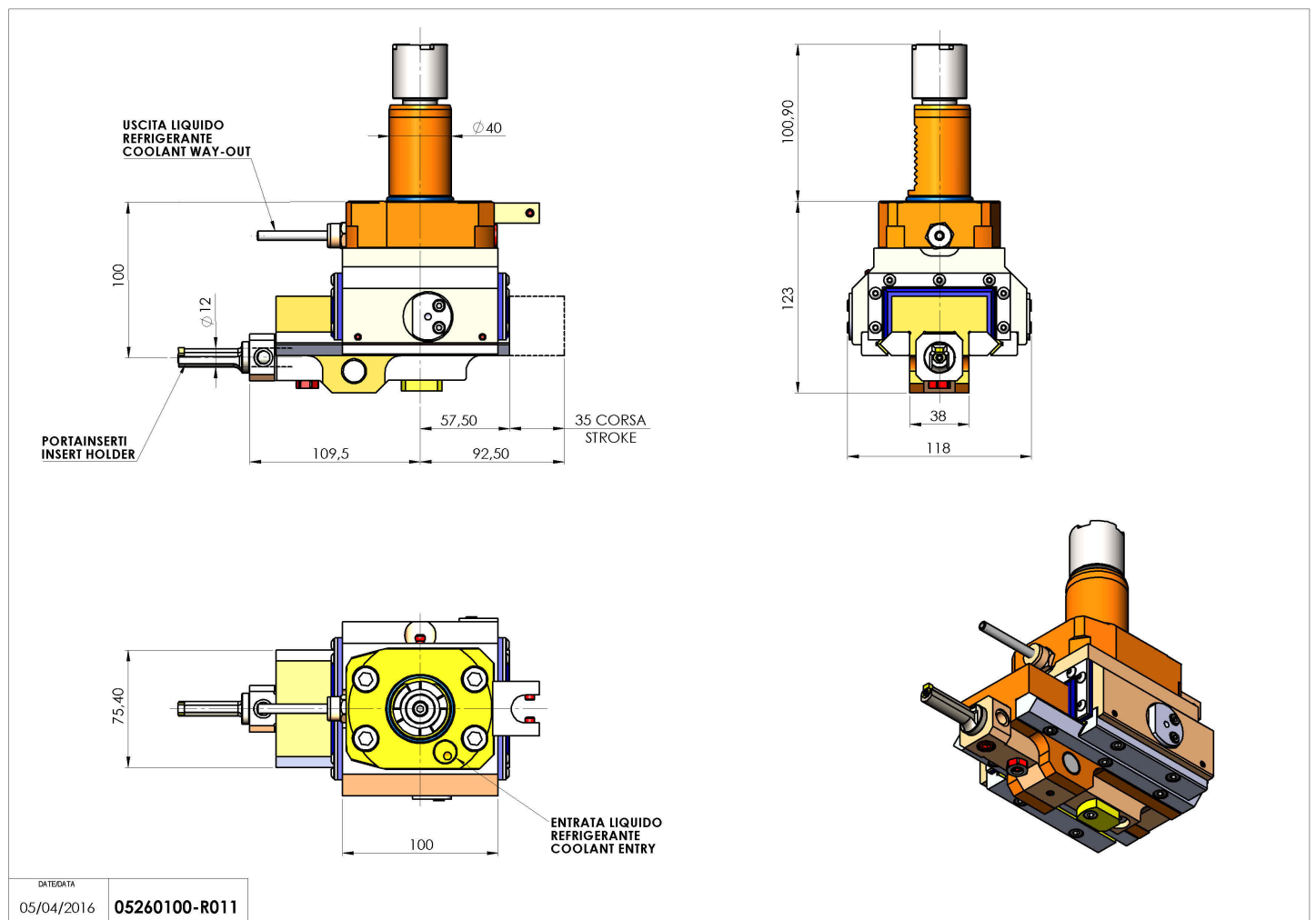

Subject to technical changes