



# 05255700 - LT-S VDI40ER32FRFOFS50H105 MZH

Type	LT-S OFS Tool holder straight offset
Mounting	VDI 40
Tool output	Collet nut ER 32 F - internal nut
Coolant	Internal coolant
Offset [mm]	50
Direction of rotation	r1  r2 
Max speed [rpm]	6000
Max torque [Nm]	63
Ratio	1:1
H [mm]	105
Max pressure [bar]	20
Accessories	N.A.
Notes	N.A.
Mounting tips	Secondary spindle only

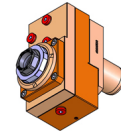

**ATTENTION: CHECK THE ORIENTATION OF THE VDI TEETH**

Always check live tool dimensions on the turret

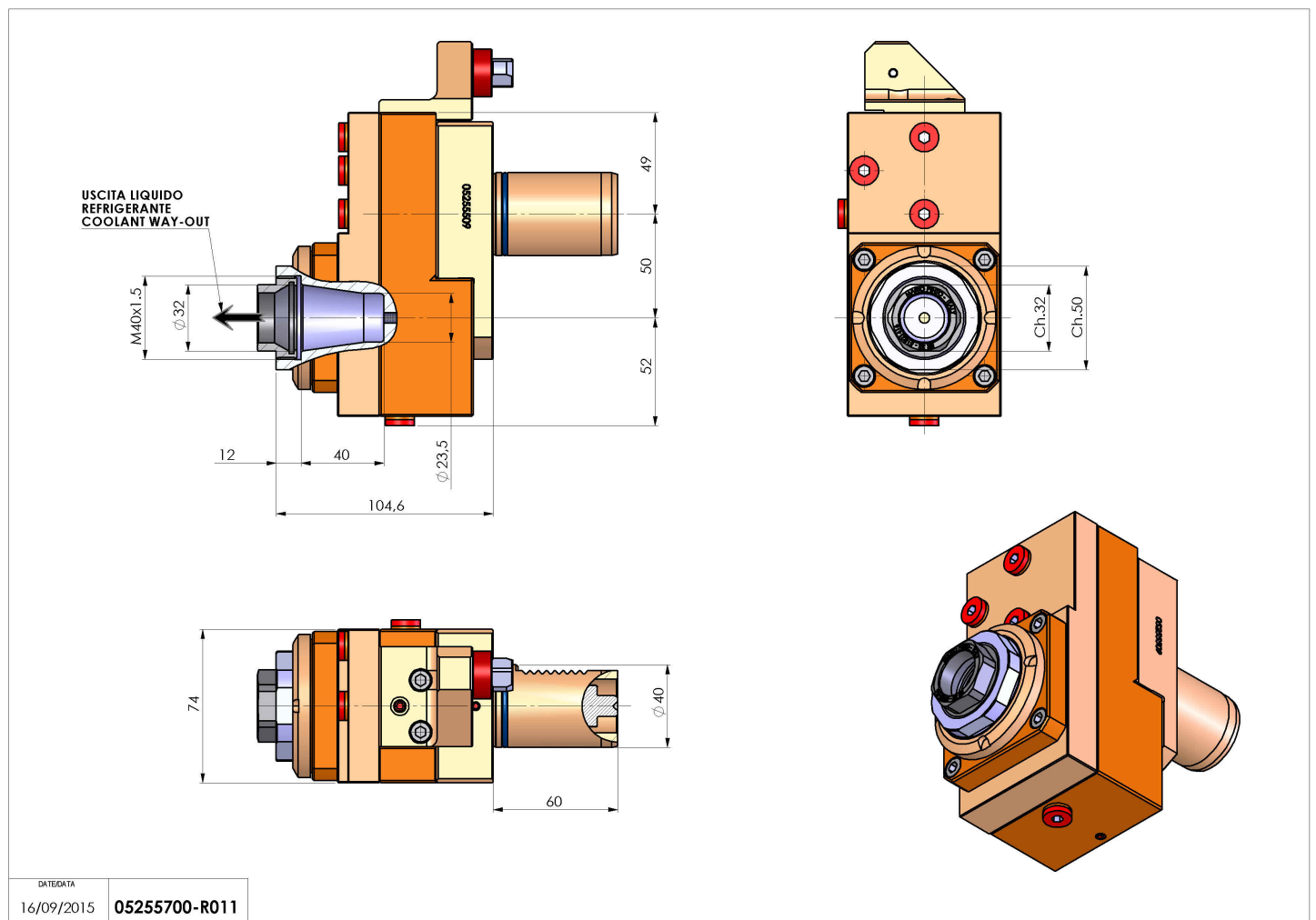

DATE/DATE	16/09/2015	05255700-R011
-----------	------------	---------------

Subject to technical changes