

# 05255300 - LT-S2VDI40ER20F-20FH122 1:2MZH

Type	LT-S2 Tool holder double straight
Mounting	VDI 40
Tool output	Collet nut ER 20 F - internal nut
Coolant	External coolant
Direction of rotation	r1 ↻ r2 ↻ r3 ↻
Max speed [rpm]	in 6000 / out 12000
Max torque [Nm]	in 38 / out 16
Ratio	1:2
H [mm]	122
Accessories	N.A.
Notes	N.A.
Mounting tips	N.A.

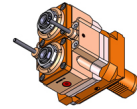

**ATTENTION: CHECK THE ORIENTATION OF THE VDI TEETH**

Always check live tool dimensions on the turret

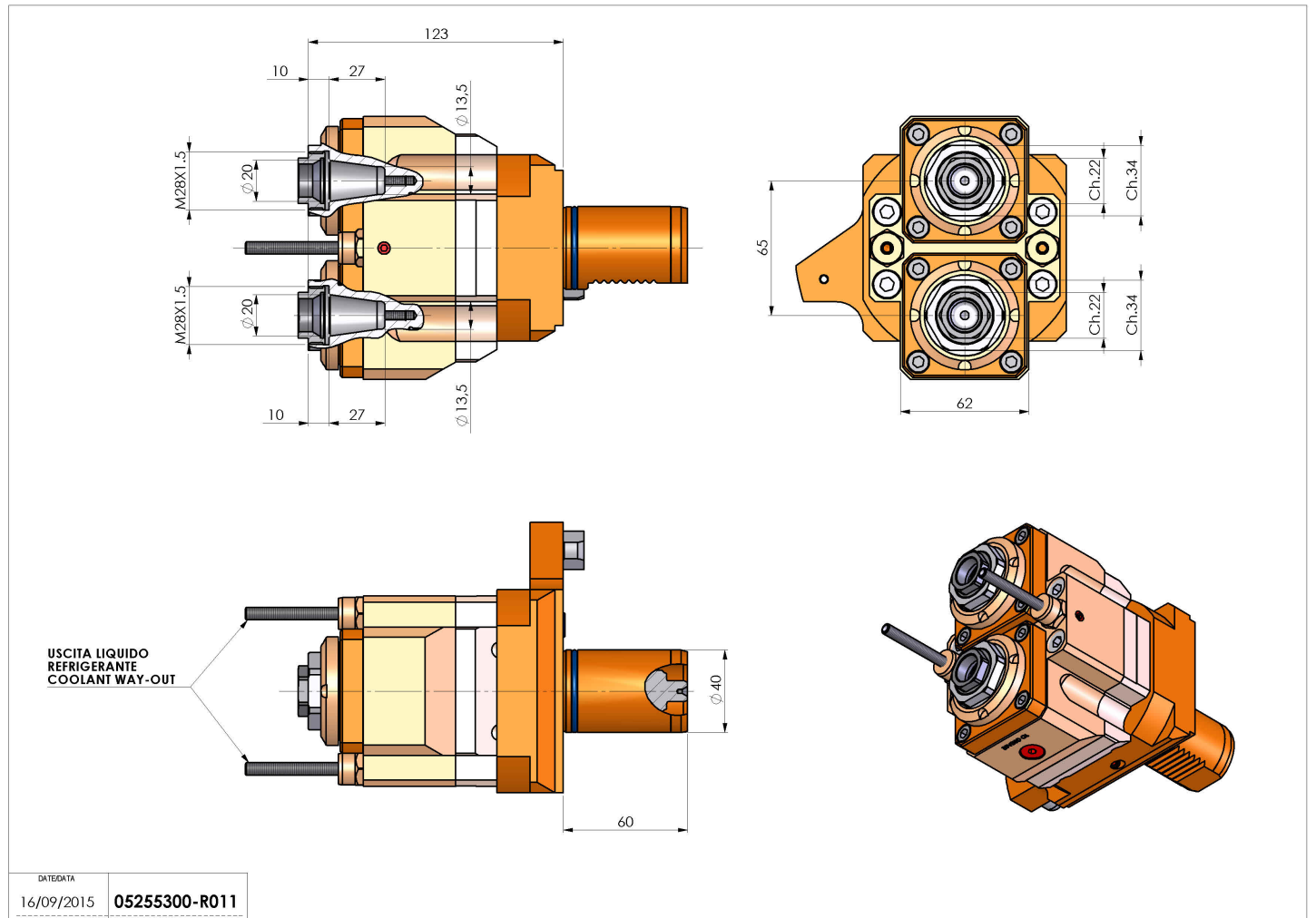

DATE/GRA  
16/09/2015 05255300-R011

Subject to technical changes