

## 05254600 - LT-A VDI50 ER40 RF H175 MZ

Type	LT-A Tool holder angle 90°
Mounting	VDI 50
Tool output	Collet nut ER 40
Coolant	Internal coolant
Direction of rotation	r1 ↻ r2 ↻
Max speed [rpm]	6000
Max torque [Nm]	63
Ratio	1:1
H [mm]	175
H1 [mm]	43
Max pressure [bar]	20
Accessories	N.A.
Notes	N.A.
Mounting tips	N.A.

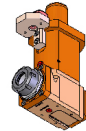

**ATTENTION: CHECK THE ORIENTATION OF THE VDI TEETH**

Always check live tool dimensions on the turret

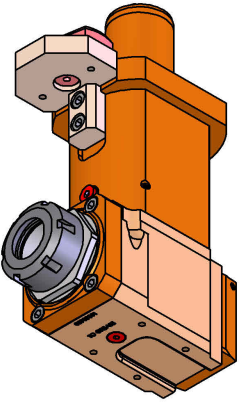
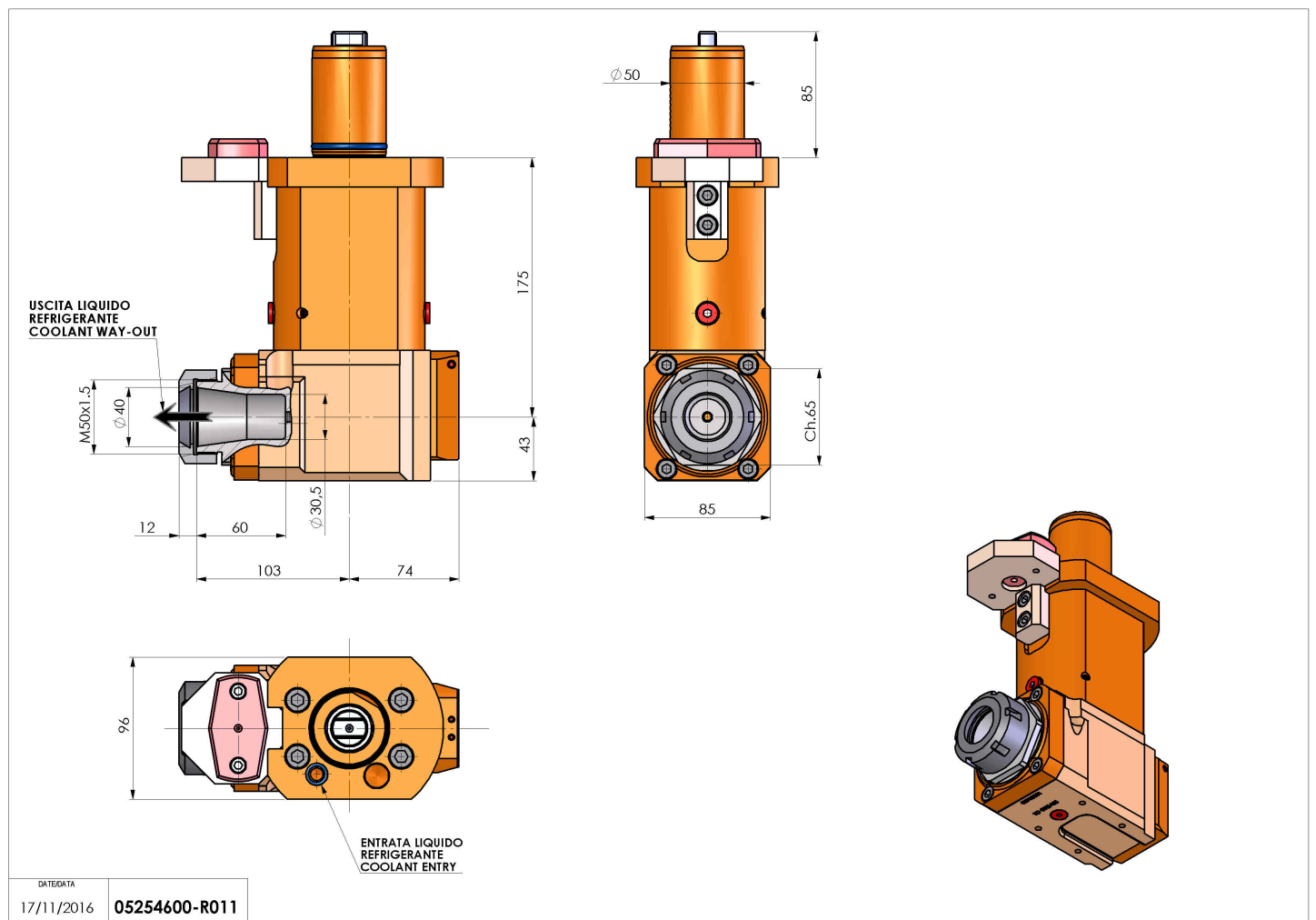

DATE/GATE  
17/11/2016 05254600-R011

Subject to technical changes