

## 05254400 - LT-A2 VDI50 HSK40 H160-84

Type	LT-A2 V Tool holder angle 90° double vertical
Mounting	VDI 50
Tool output	Quick Change HSK40
Coolant	External coolant
Direction of rotation	r1 ↻ r2 ↻
Max speed [rpm]	4000
Max torque [Nm]	50
Ratio	1:1
H [mm]	84-160
H1 [mm]	39
Accessories	N.A.
Notes	N.A.
Mounting tips	N.A.

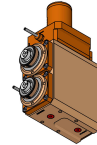

**ATTENTION: CHECK THE ORIENTATION OF THE VDI TEETH**

Always check live tool dimensions on the turret

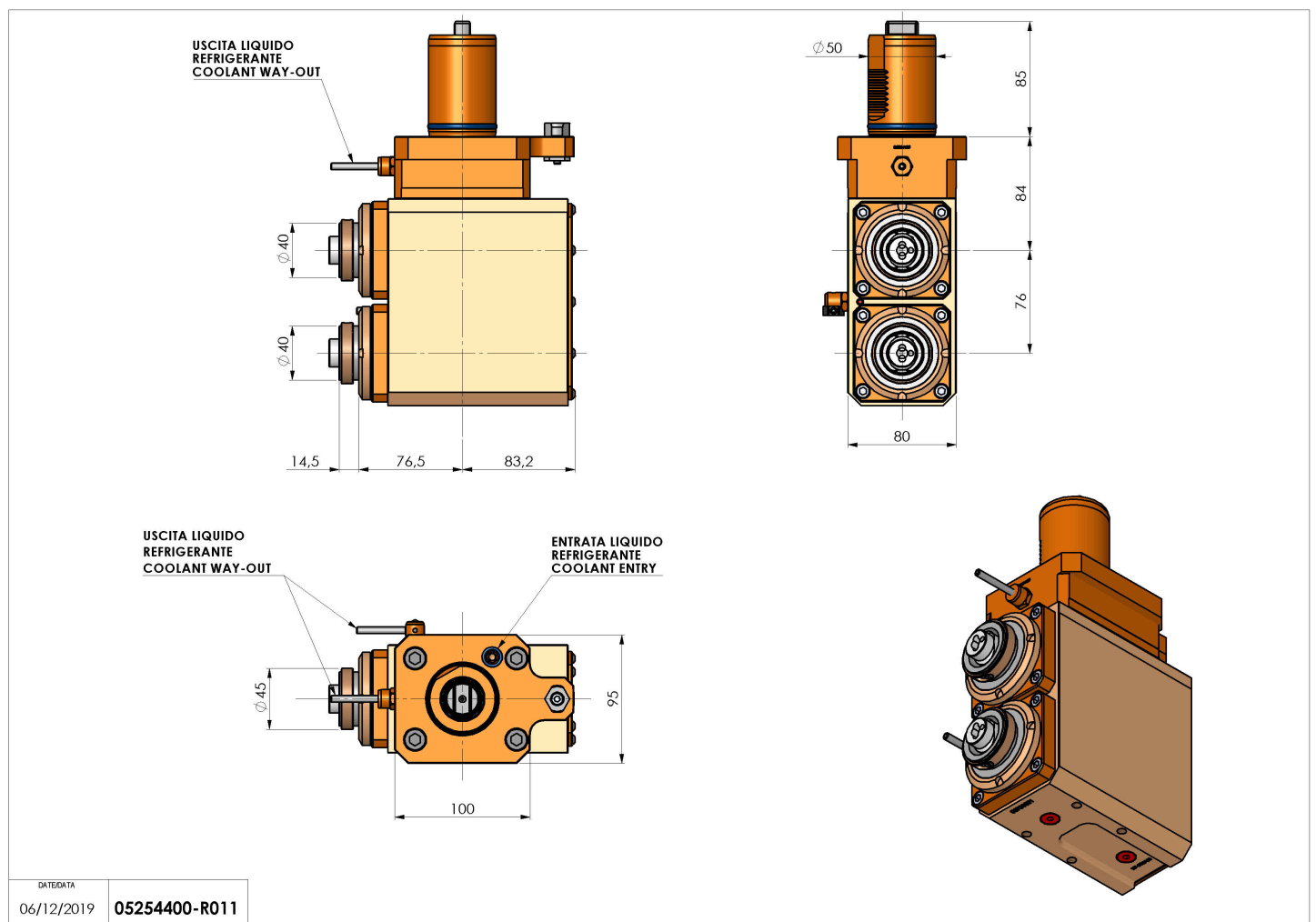

DATE/DATE	06/12/2019	05254400-R011
-----------	------------	---------------

Subject to technical changes