

05252400 - LT-A VDI50 CAT40V40 L2:1H160MZ

Type	LT-A Tool holder angle 90°
Mounting	VDI 50
Tool output	Quick Change CAT40
Coolant	External coolant
Direction of rotation	r1 ↻ r2 ↻
Max speed [rpm]	in 6000 / out 3000
Max torque [Nm]	in 60 / out 120
Ratio	2:1
H [mm]	160
H1 [mm]	52
Accessories	N.A.
Notes	N.A.
Mounting tips	N.A.

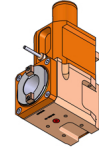

ATTENTION: CHECK THE ORIENTATION OF THE VDI TEETH

Always check live tool dimensions on the turret

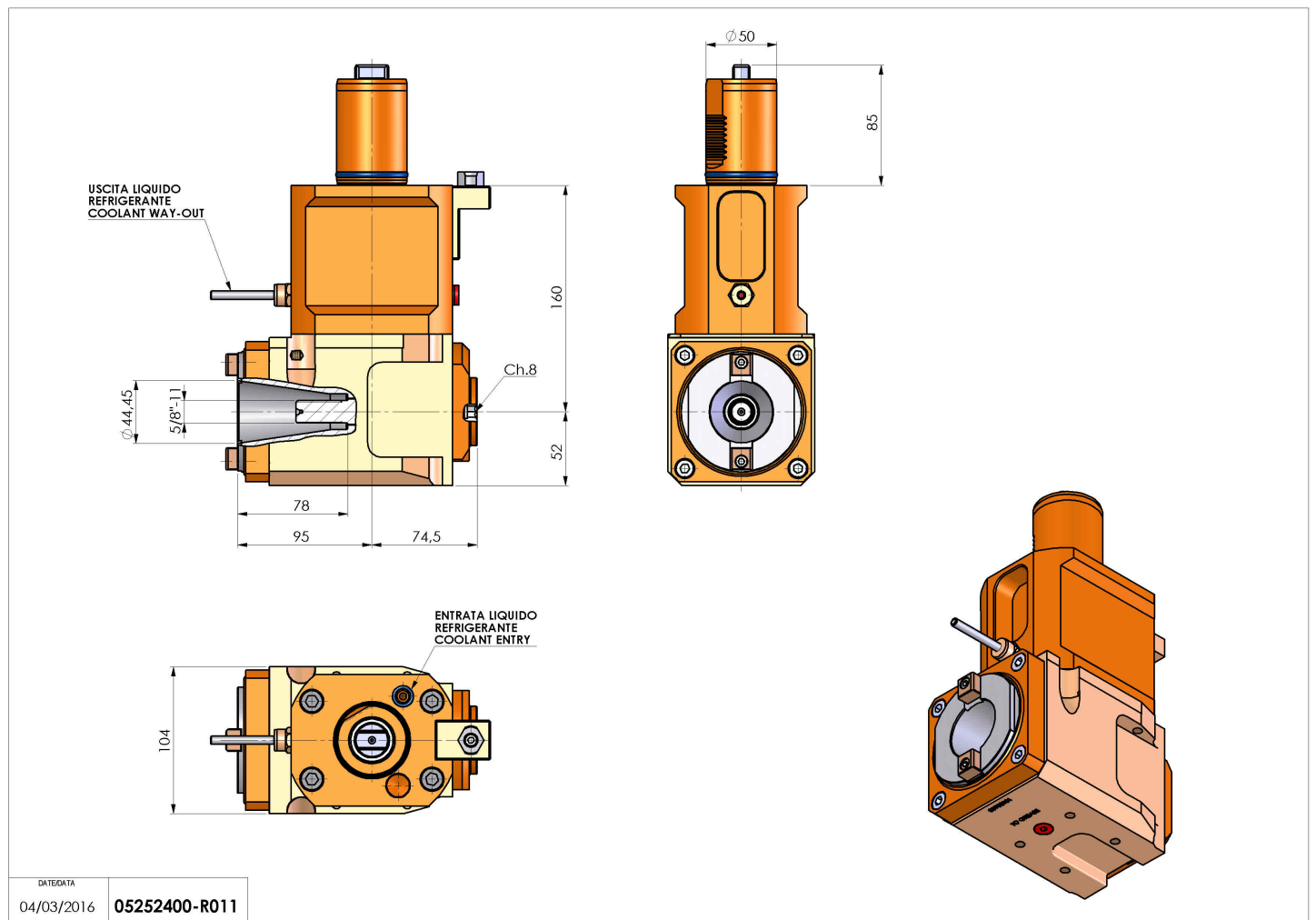

DATE/DATE
04/03/2016 **05252400-R011**

Subject to technical changes