

05251600 - LT-S2VDI40ER20F-20F H122 1:1MZ

Type	LT-S2 Tool holder double straight
Mounting	VDI 40
Tool output	Collet nut ER 20 F - internal nut
Coolant	External coolant
Direction of rotation	r1 ↻ r2 ↻
Max speed [rpm]	6000
Max torque [Nm]	38
Ratio	1:1
H [mm]	122
Accessories	N.A.
Notes	N.A.
Mounting tips	N.A.

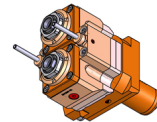

ATTENTION: CHECK THE ORIENTATION OF THE VDI TEETH

Always check live tool dimensions on the turret

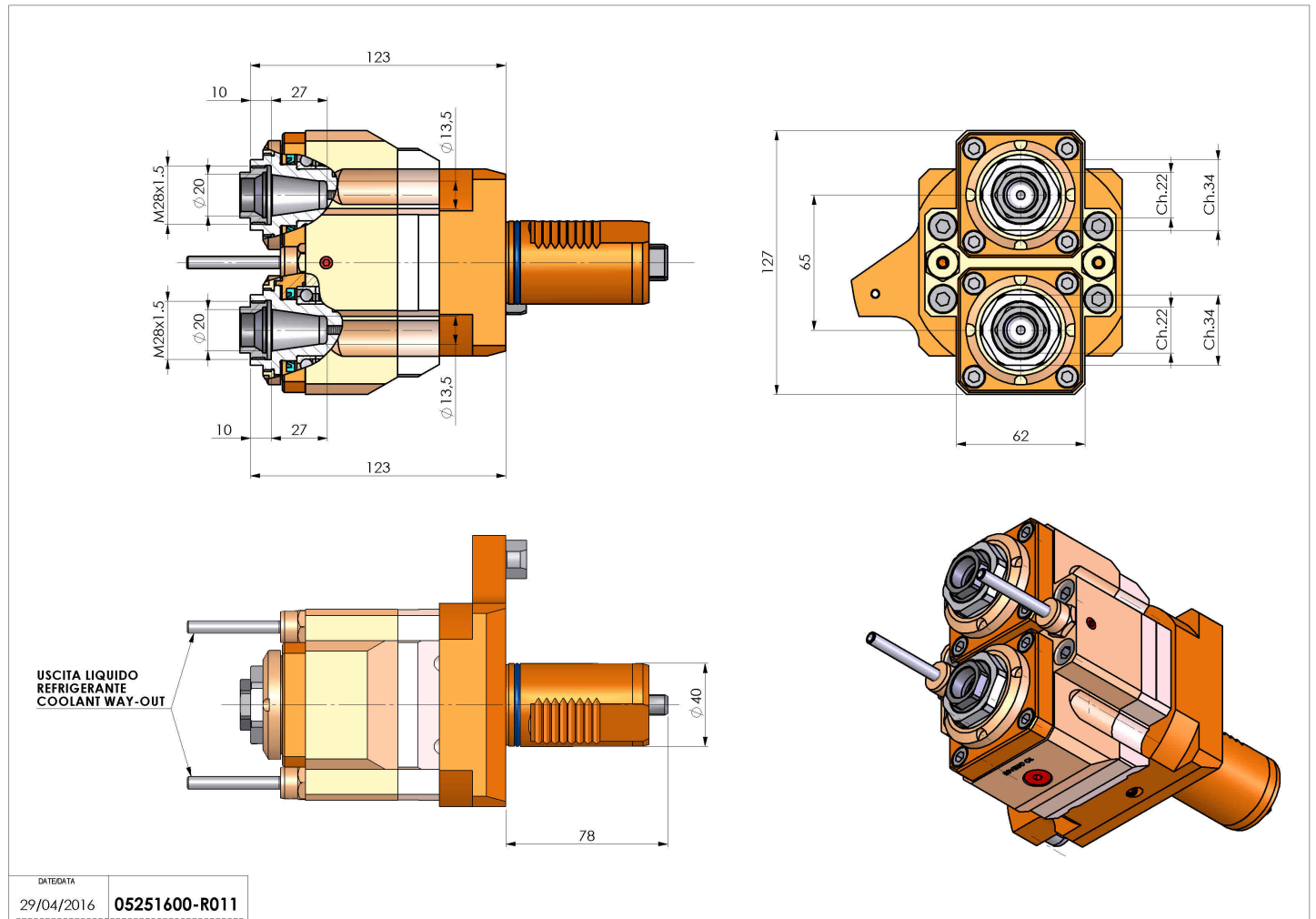

Subject to technical changes