

05248500 - LT-A VDI50 ER40 OFS LR H90

Type	LT-A OFS Tool holder offset angle 90°
Mounting	VDI 50
Tool output	Collet nut ER 40
Coolant	External coolant
Direction of rotation	r1 ↻ r2 ↻
Max speed [rpm]	6000
Max torque [Nm]	50
Ratio	1:1
H [mm]	90
H1 [mm]	43
Accessories	N.A.
Notes	N.A.
Mounting tips	N.A.

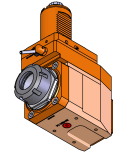

ATTENTION: CHECK THE ORIENTATION OF THE VDI TEETH

Always check live tool dimensions on the turret

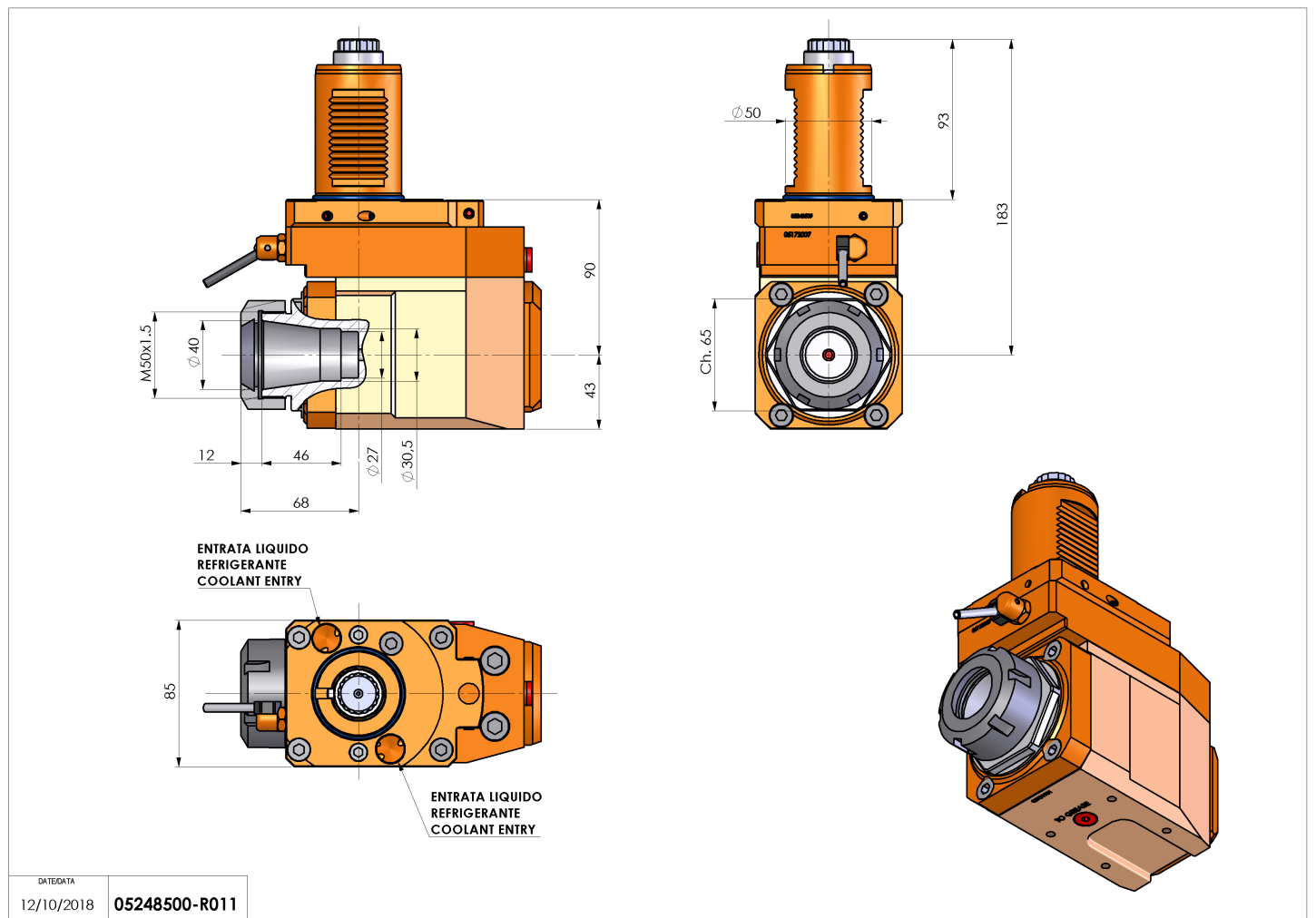

DATE/ATA	12/10/2018	05248500-R011
----------	------------	---------------

Subject to technical changes