



05248400 - LT-S D40 ER32F HRF HS H83

Type	LT-S Tool holder straight
Mounting	CYLINDRICAL SHANK 40
Tool output	Collet nut ER 32 F - internal nut
Coolant	HRF Internal coolant
Direction of rotation	r1  r2 
Max speed [rpm]	10000
Max torque [Nm]	40
Ratio	1:1
H [mm]	83
Max pressure [bar]	70
Accessories	N.A.
Notes	N.A.
Mounting tips	N.A.



Always check live tool dimensions on the turret

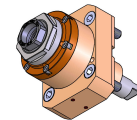
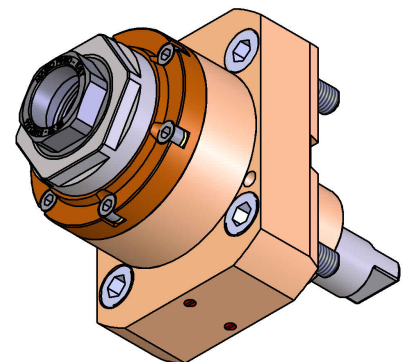
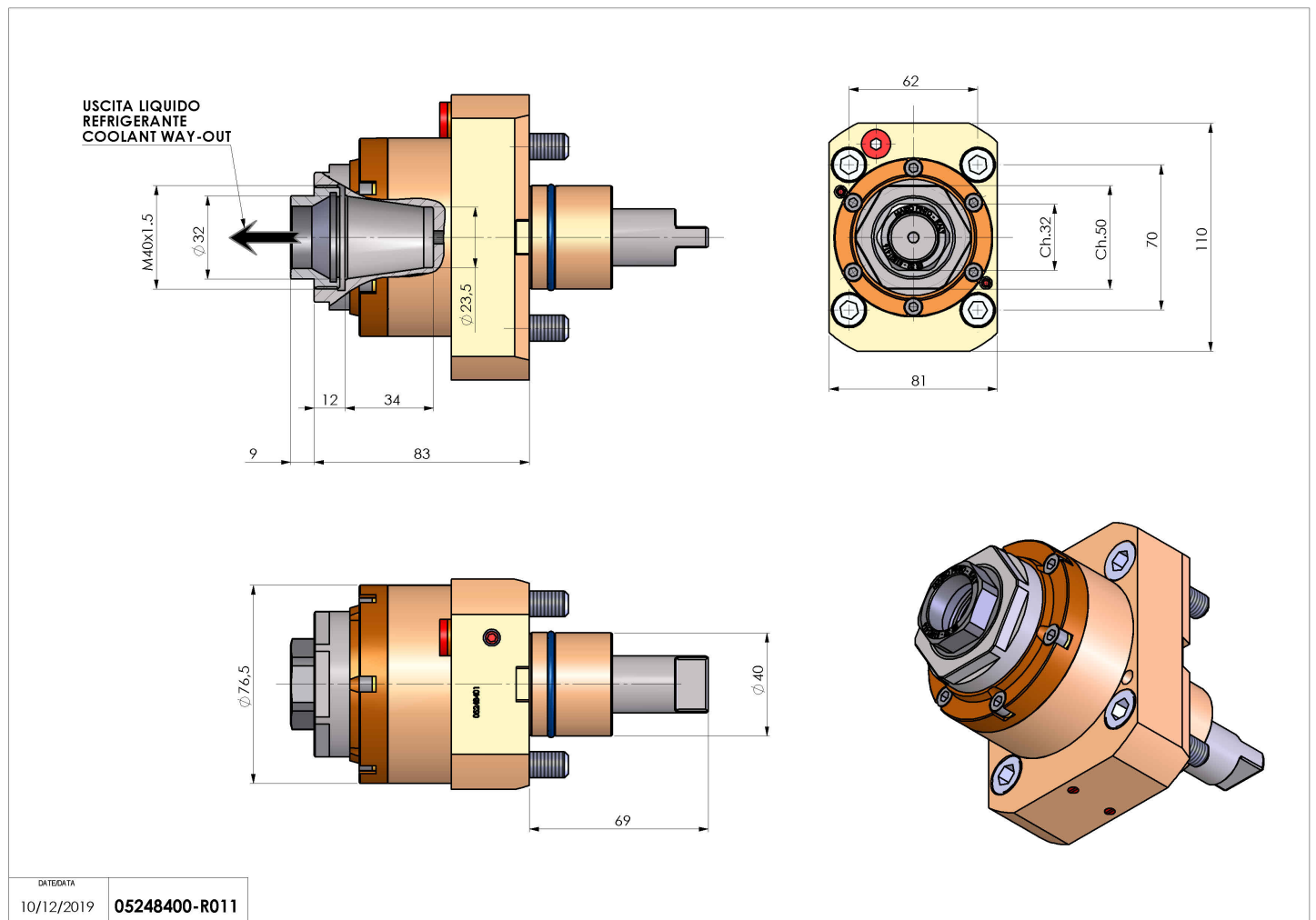

DATE/DATE	10/12/2019
	05248400-R011

Subject to technical changes