

05246100 - LT-S D40 ER25F OFS90 RF H82 MS

Type	LT-S OFS Tool holder straight offset
Mounting	CYLINDRICAL SHANK 40
Tool output	Collet nut ER 25 F - internal nut
Coolant	Internal coolant
Offset [mm]	90
Direction of rotation	r1 ↻ r2 ↻
Max speed [rpm]	6000
Max torque [Nm]	40
Ratio	1:1
H [mm]	81,5
Max pressure [bar]	20
Accessories	N.A.
Notes	N.A.
Mounting tips	N.A.

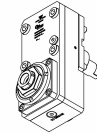

REPLACED BY 05247400

Always check live tool dimensions on the turret

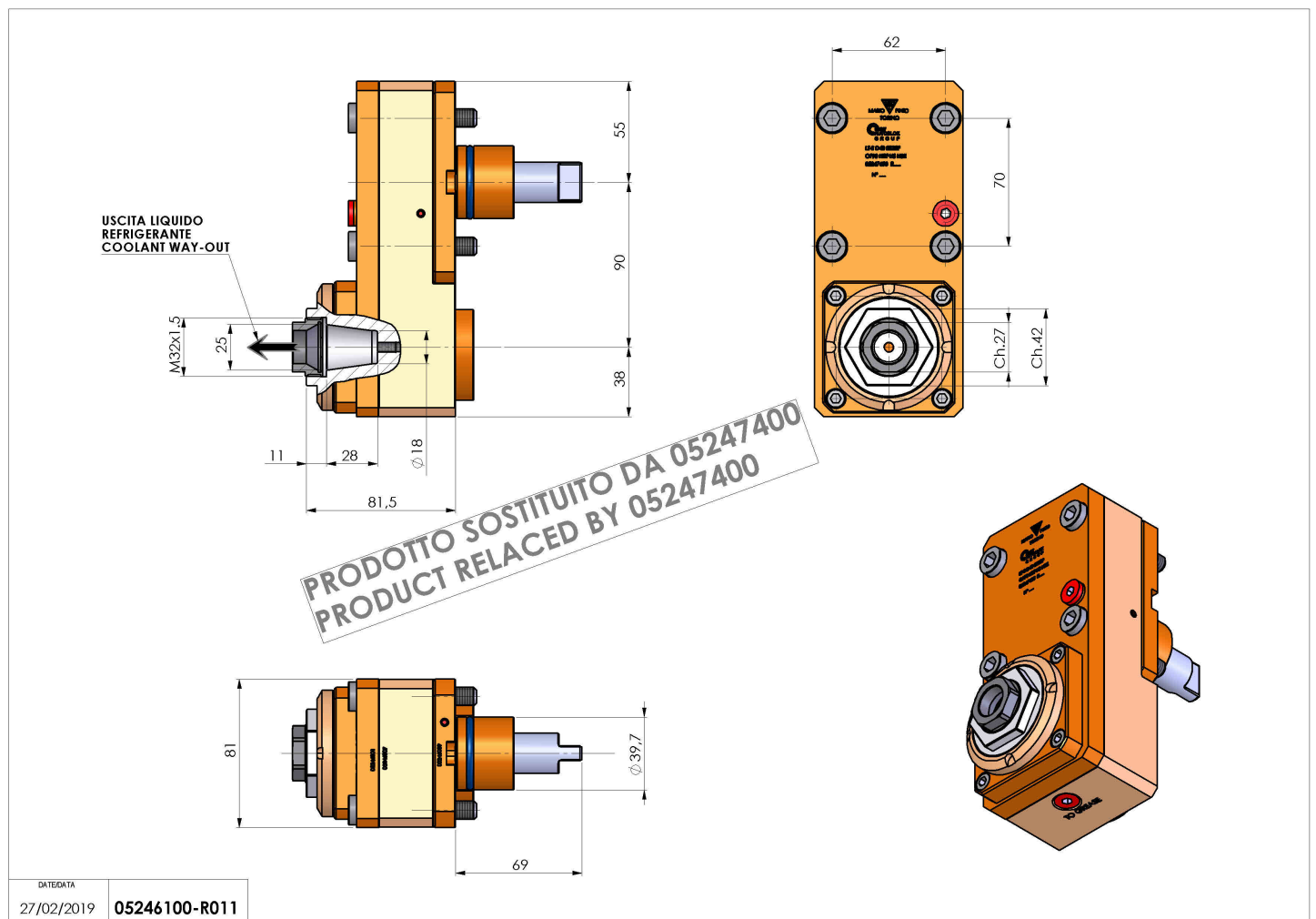

Subject to technical changes