

## 05245300 - LT-A D40 ER25F RF H85

Type	LT-A Tool holder angle 90°
Mounting	CYLINDRICAL SHANK 40
Tool output	Collet nut ER 25 F - internal nut
Coolant	Internal coolant
Direction of rotation	r1 ↻ r2 ↻
Max speed [rpm]	6000
Max torque [Nm]	40
Ratio	1:1
H [mm]	85
H1 [mm]	32,5
Max pressure [bar]	20
Accessories	N.A.
Notes	N.A.
Mounting tips	N.A.

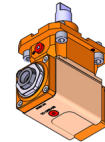

Always check live tool dimensions on the turret

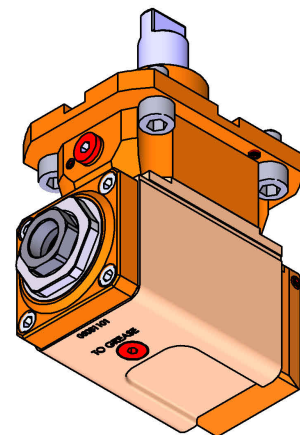
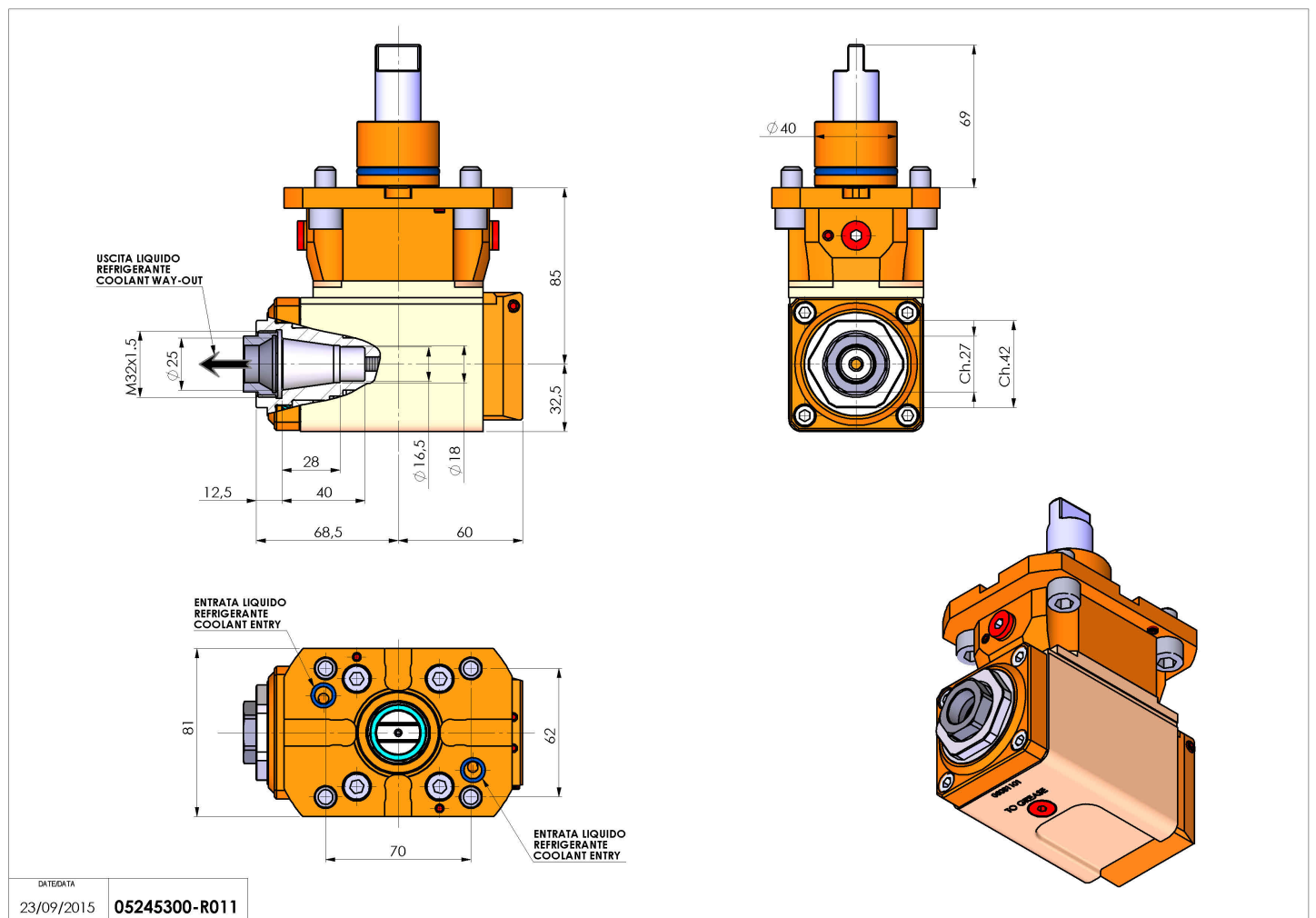

DATE/DATE  
23/09/2015 05245300-R011

Subject to technical changes