

05244200 - LT-A D40 ER20-20 H85

Type	LT-A DBL Tool holder double angle 90°
Mounting	CYLINDRICAL SHANK 40
Tool output	Collet nut ER 20
Coolant	External coolant
Direction of rotation	r1 ↻ r2 ↻ r3 ↻
Max speed [rpm]	6000
Max torque [Nm]	40
Ratio	1:1
H [mm]	85
H1 [mm]	37
Accessories	N.A.
Notes	N.A.
Mounting tips	N.A.

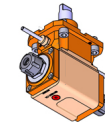

Always check live tool dimensions on the turret

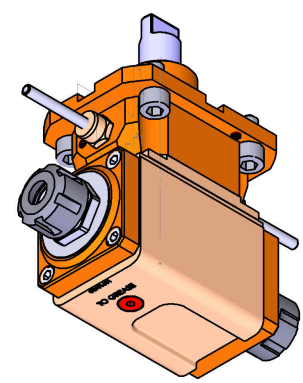
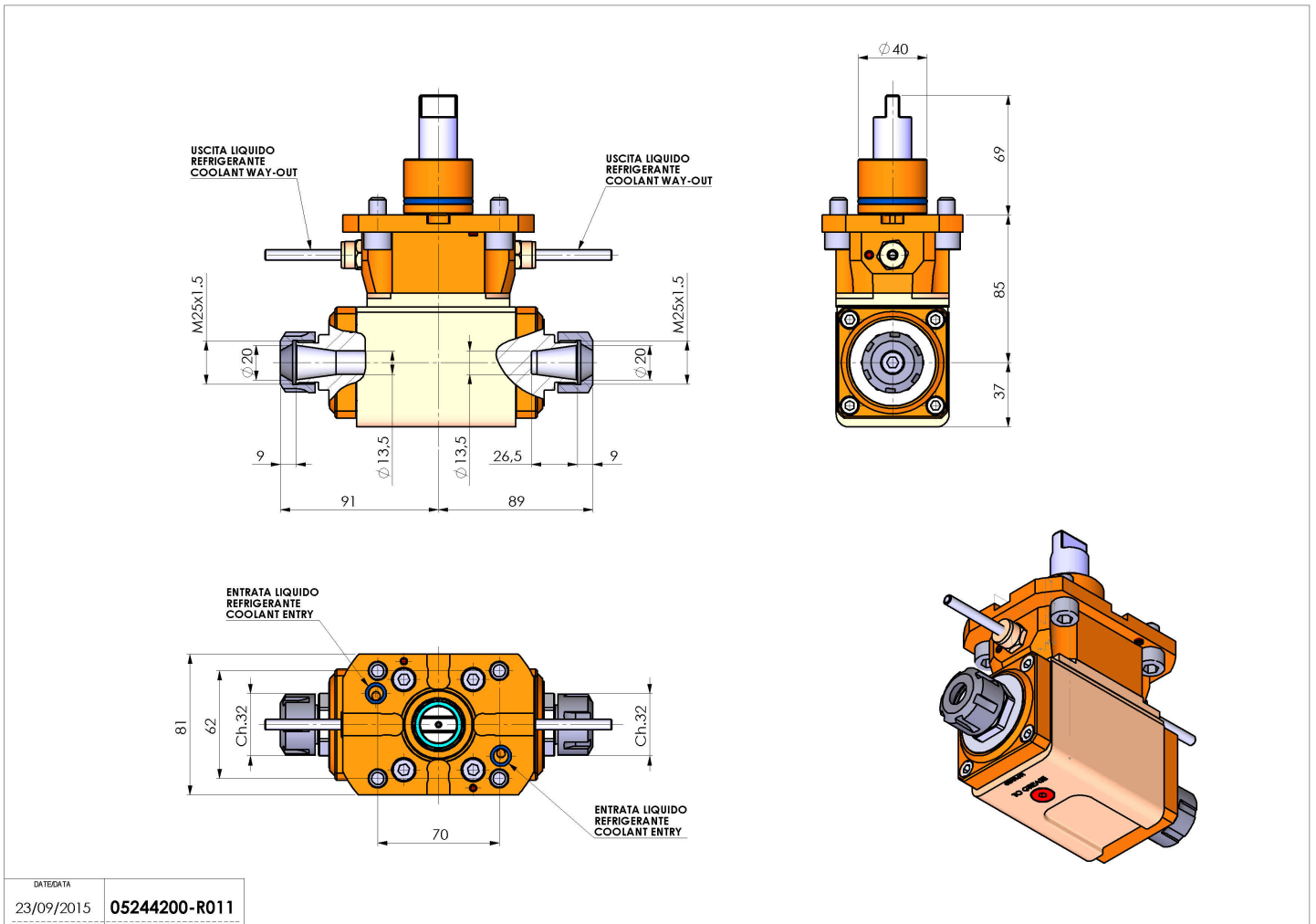

DATE/DATA	05244200-R011
23/09/2015	

Subject to technical changes