



05242800 - LT-S D40 ER25F RF HS H65

Type	LT-S Tool holder straight
Mounting	CYLINDRICAL SHANK 40
Tool output	Collet nut ER 25 F - internal nut
Coolant	Internal coolant
Direction of rotation	r1  r2 
Max speed [rpm]	12000
Max torque [Nm]	40
Ratio	1:1
H [mm]	65
Max pressure [bar]	20
Accessories	N.A.
Notes	N.A.
Mounting tips	N.A.



Always check live tool dimensions on the turret

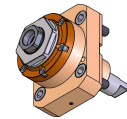
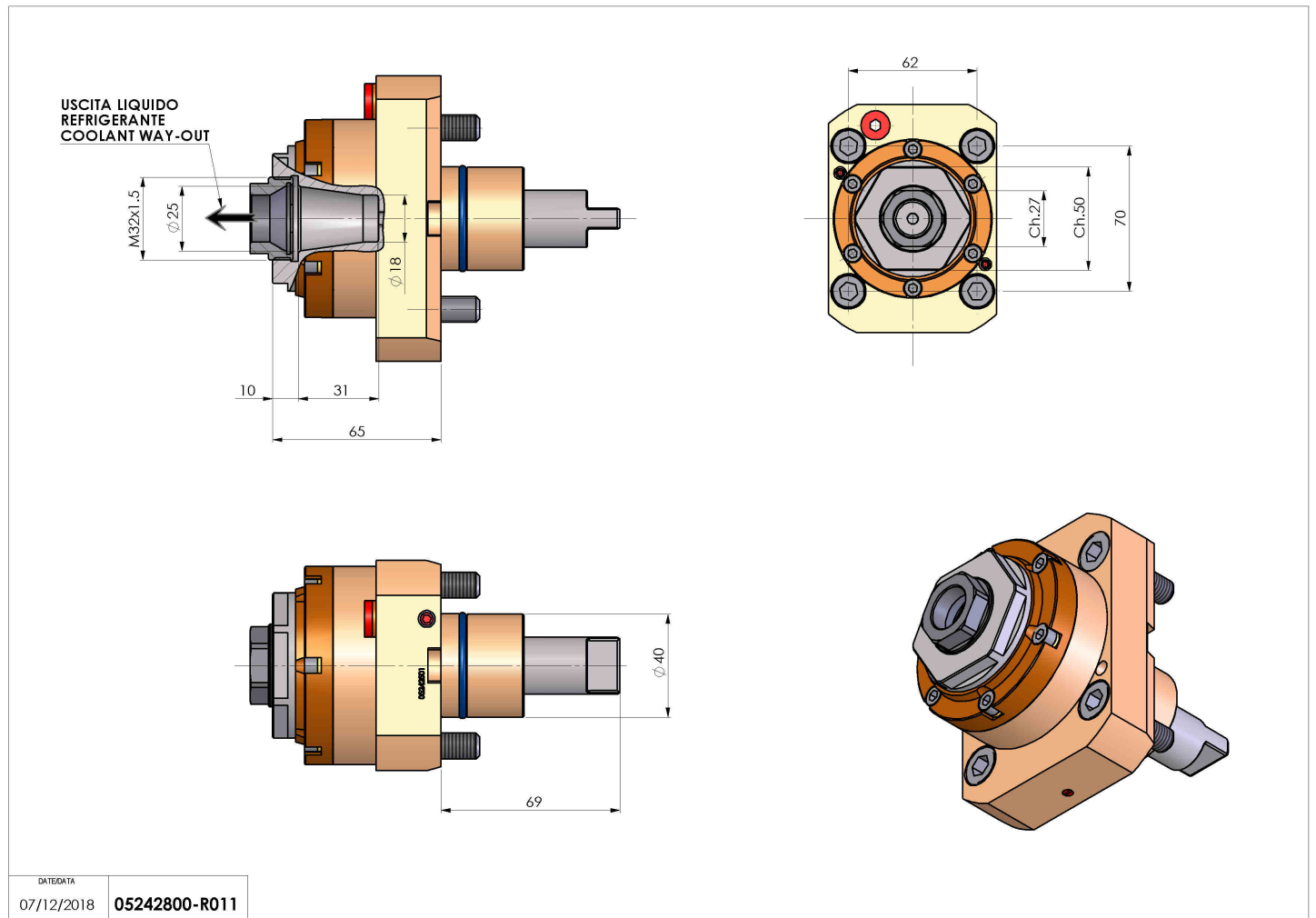

DATE/DATE
07/12/2018 05242800-R011

Subject to technical changes