



05232100 - LT-S VDI40 ER20F HRF H83 EM

Type	LT-S Tool holder straight
Mounting	VDI 40
Tool output	Collet nut ER 20 F - internal nut
Coolant	HRF Internal coolant
Direction of rotation	r1  r2 
Max speed [rpm]	10000
Max torque [Nm]	63
Ratio	1:1
H [mm]	83
Max pressure [bar]	70
Accessories	N.A.
Notes	N.A.
Mounting tips	N.A.

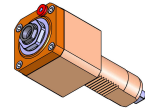

ATTENTION: CHECK THE ORIENTATION OF THE VDI TEETH

Always check live tool dimensions on the turret

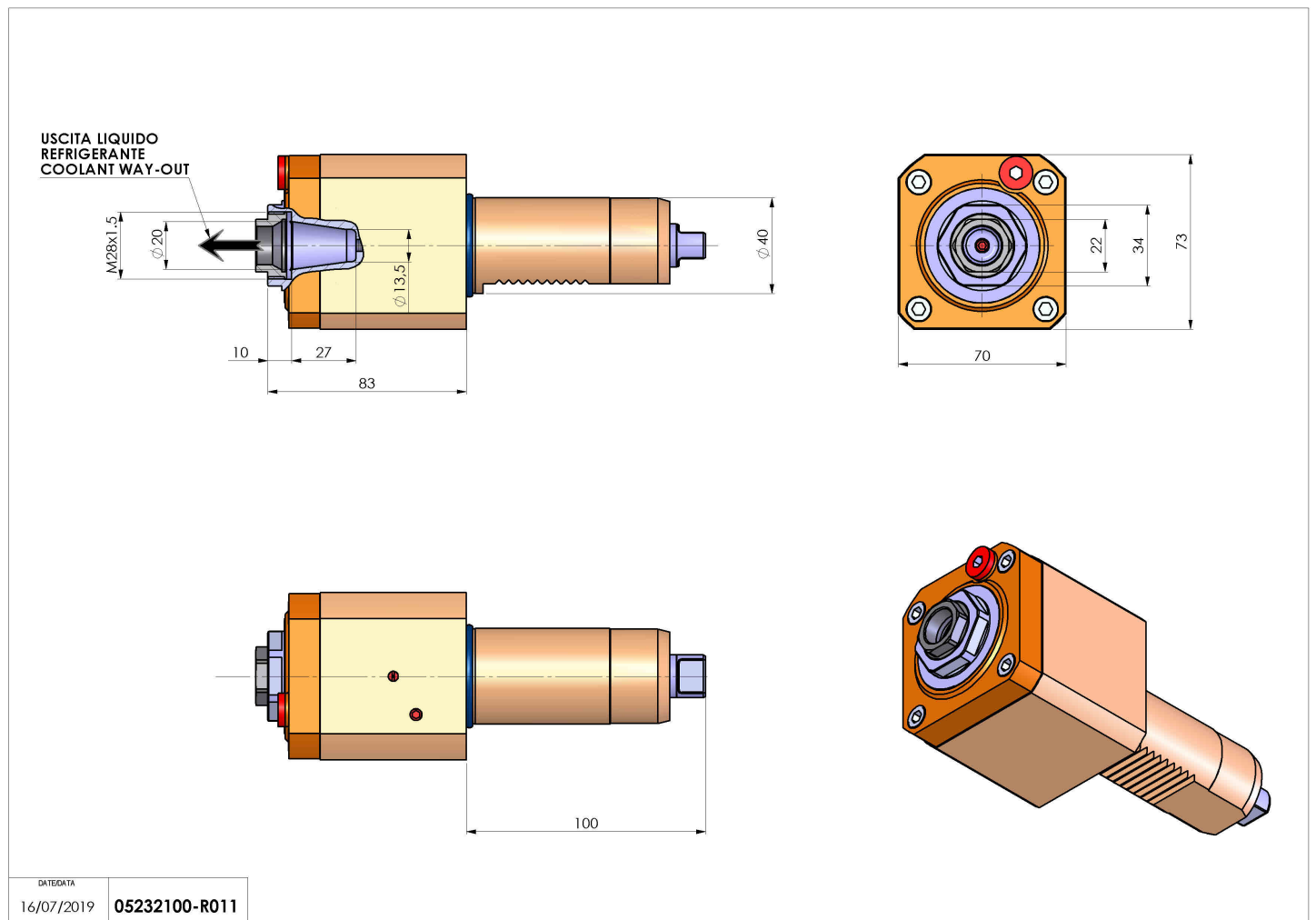

Subject to technical changes