

05230500 - LT-A VDI50 ER40F HRF H80

Type	LT-A Tool holder angle 90°
Mounting	VDI 50
Tool output	Collet nut ER 40 F - internal nut
Coolant	HRF Internal coolant
Direction of rotation	r1 ↻ r2 ↻
Max speed [rpm]	6000
Max torque [Nm]	100
Ratio	1:1
H [mm]	80
H1 [mm]	43
Max pressure [bar]	80
Accessories	N.A.
Notes	N.A.
Mounting tips	N.A.

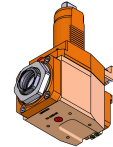

ATTENTION: CHECK THE ORIENTATION OF THE VDI TEETH

Always check live tool dimensions on the turret

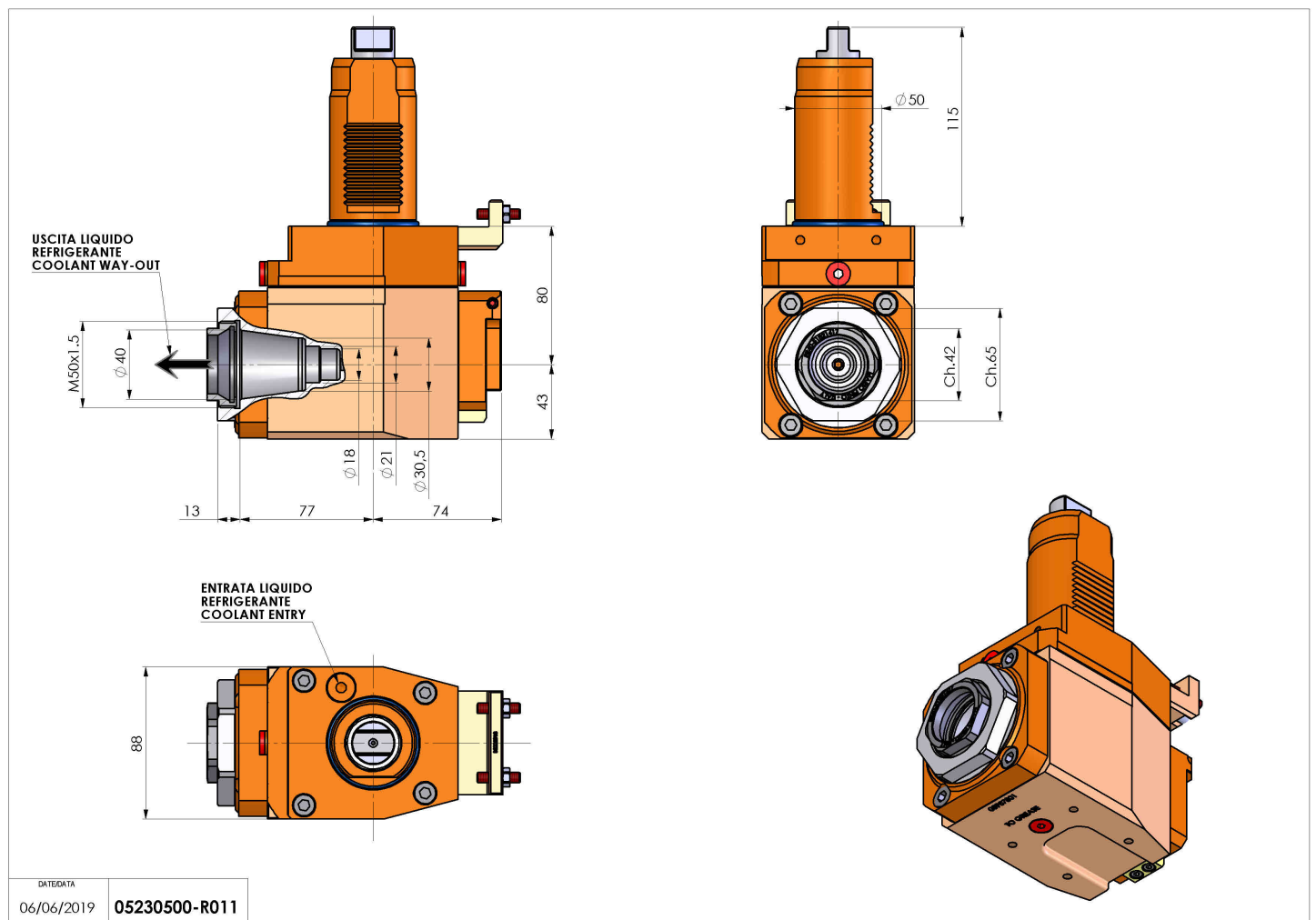

Subject to technical changes