

05230300 - LT-S VDI50 ER32F RF H95

Type	LT-S Tool holder straight
Mounting	VDI 50
Tool output	Collet nut ER 32 F - internal nut
Coolant	Internal coolant
Direction of rotation	r1 r2
Max speed [rpm]	6000
Max torque [Nm]	100
Ratio	1:1
H [mm]	95
Max pressure [bar]	20
Accessories	N.A.
Notes	N.A.
Mounting tips	N.A.

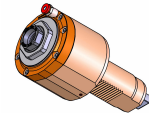

ATTENTION: CHECK THE ORIENTATION OF THE VDI TEETH

Always check live tool dimensions on the turret

USCITA LIQUIDO REFRIGERANTE
COOLANT WAY-OUT

DATE/DATA
28/02/2017
05230300-R011

Subject to technical changes