

05229000 - LT-A ST25 VDI30 C12 CR-AY H105 5480

Type	LT-A ST Slotting tool 90°
Mounting	VDI 30
Tool output	Tool diameter 12
Coolant	External coolant
Max speed [rpm]	700
Max torque [Nm]	17,5
Ratio	1:1
Y axis adjustment	SI
Feed pushing [N]	1000
Stroke [mm]	25
Work stroke [mm]	20
Y axis adjust. [mm]	±0,4
H [mm]	105
Accessories	N.A.
Notes	N.A.
Mounting tips	Right star-type turret

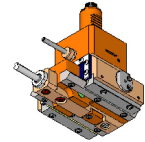

ATTENTION: CHECK THE ORIENTATION OF THE VDI TEETH

Always check live tool dimensions on the turret

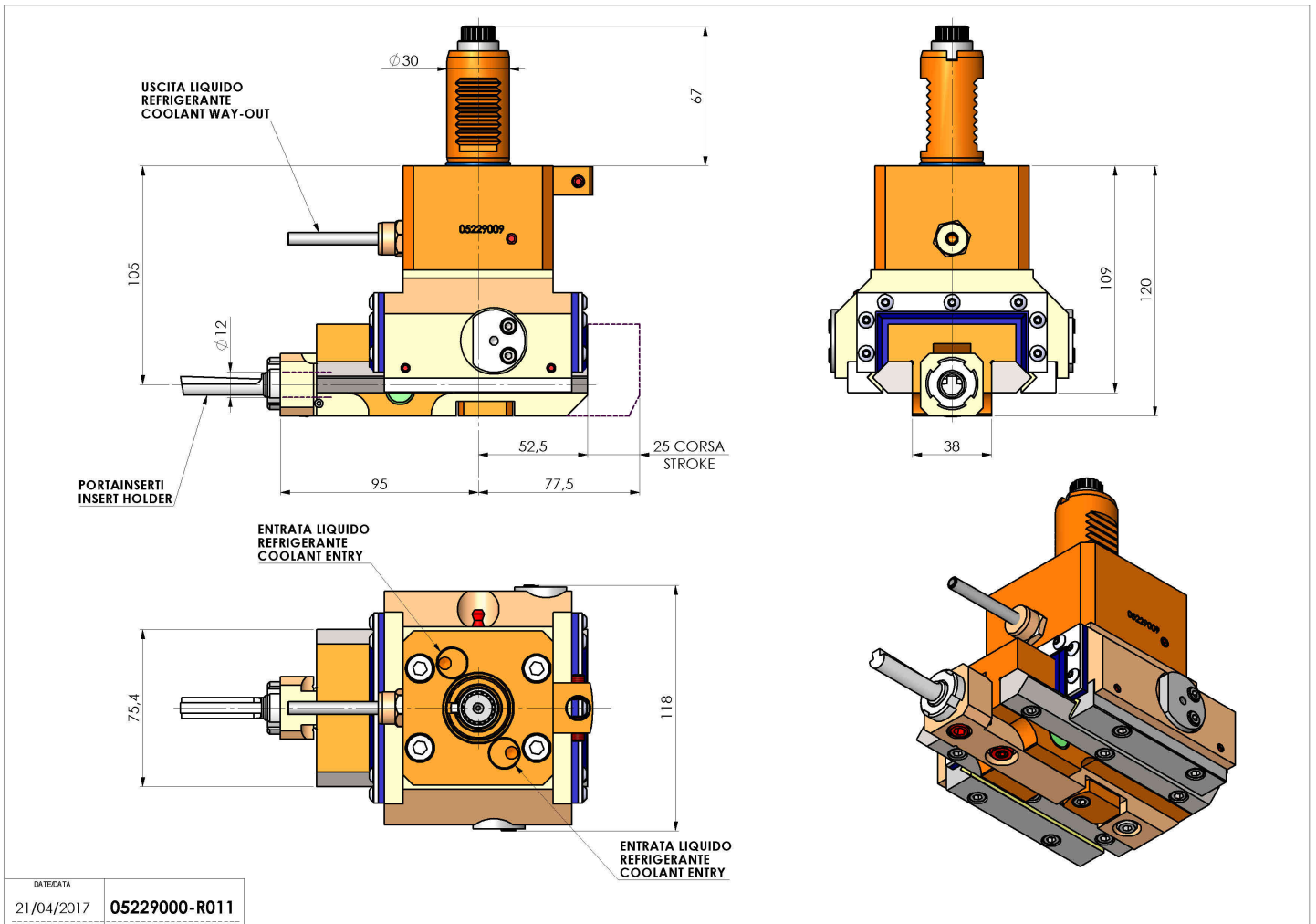

DATE/GATE	05229000-R011
21/04/2017	

Subject to technical changes