

05227900 - LT-A2 VDI40 W-16 1:1 5480SA

| | |
|-----------------------|--|
| Type | LT-A2 H Tool holder angle 90° double horizontal |
| Mounting | VDI 40 |
| Tool output | Weldon 16 DIN1835B |
| Coolant | External coolant |
| Direction of rotation | r1 ↻ r2 ↻ |
| Max speed [rpm] | 3000 |
| Ratio | 1:1 |
| H [mm] | 63,5-103,5 |
| H1 [mm] | 27 |
| Accessories | N.A. |
| Notes | N.A. |
| Mounting tips | N.A. |

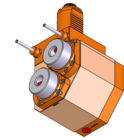

ATTENTION: CHECK THE ORIENTATION OF THE VDI TEETH

Always check live tool dimensions on the turret

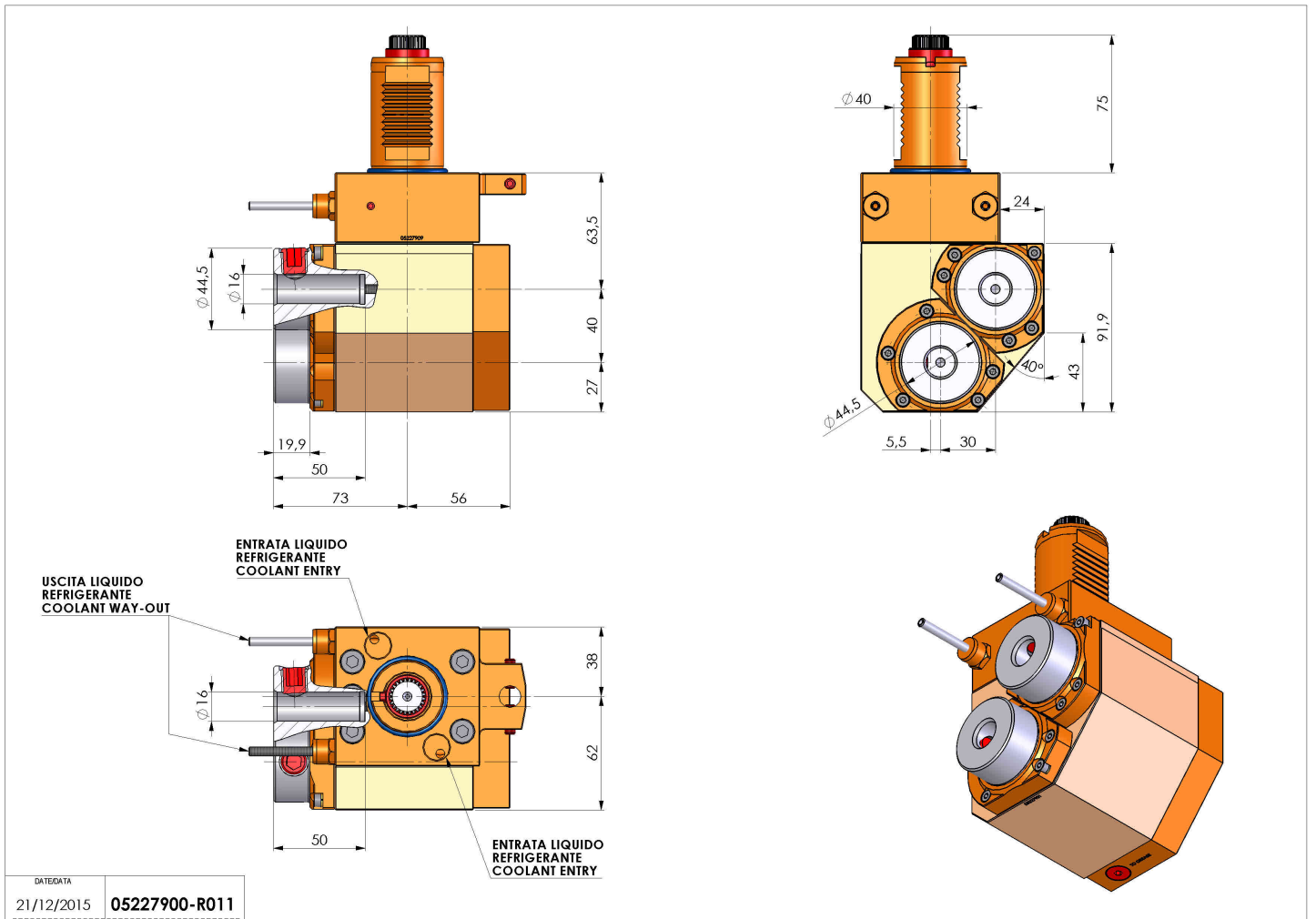

DATE/DATE
21/12/2015 05227900-R011

Subject to technical changes