

# 05226100 - LT-A D35HSK40H100 OFS-0-5480SA

<b>Type</b>	LT-A OFS Tool holder offset angle 90°
<b>Mounting</b>	CYLINDRICAL SHANK 35
<b>Tool output</b>	Quick Change HSK40
<b>Coolant</b>	External coolant
<b>Direction of rotation</b>	r1  r2
<b>Max speed [rpm]</b>	6000
<b>Max torque [Nm]</b>	30
<b>Ratio</b>	1:1
<b>H [mm]</b>	100
<b>H1 [mm]</b>	33
<b>Accessories</b>	N.A.
<b>Notes</b>	N.A.
<b>Mounting tips</b>	N.A.

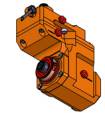

Always check live tool dimensions on the turret

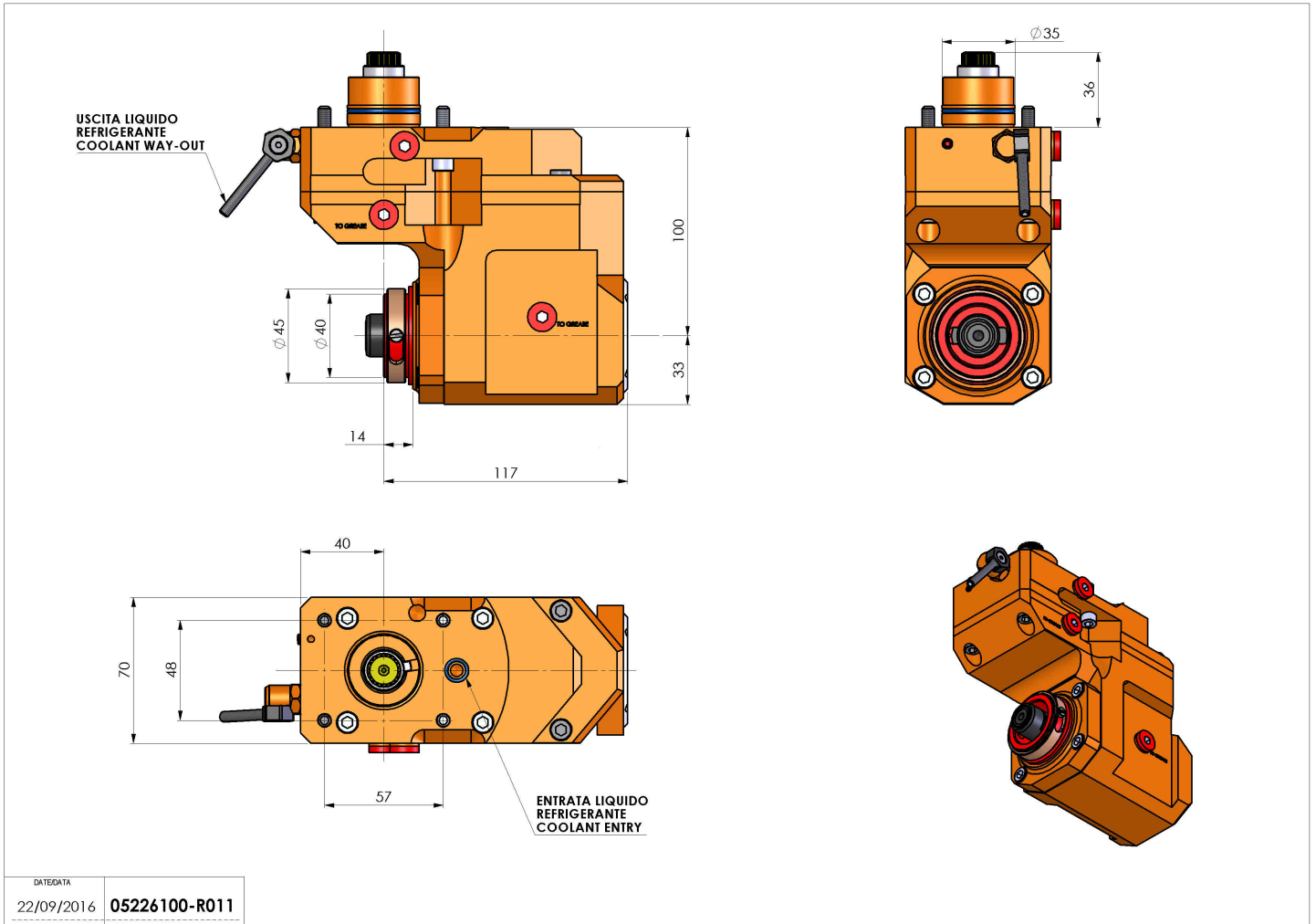

DATE/DATA	22/09/2016
PART NUMBER	05226100-R011

**Subject to technical changes**