

05225600 - LT-S2R VDI50HSK40 I-58H100-115

Type	LT-S2 Tool holder double straight
Mounting	VDI 50
Tool output	Quick Change HSK40
Coolant	External coolant
Direction of rotation	r1 ↻ r2 ↻ r3 ↻
Max speed [rpm]	in r1=6000 / out r2=6000 r3=3000
Max torque [Nm]	in r1=60 / out r2=60 r3=120
Ratio	1:1 / 2:1
H [mm]	118
Accessories	N.A.
Notes	N.A.
Mounting tips	N.A.

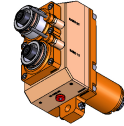

ATTENTION: CHECK THE ORIENTATION OF THE VDI TEETH

Always check live tool dimensions on the turret

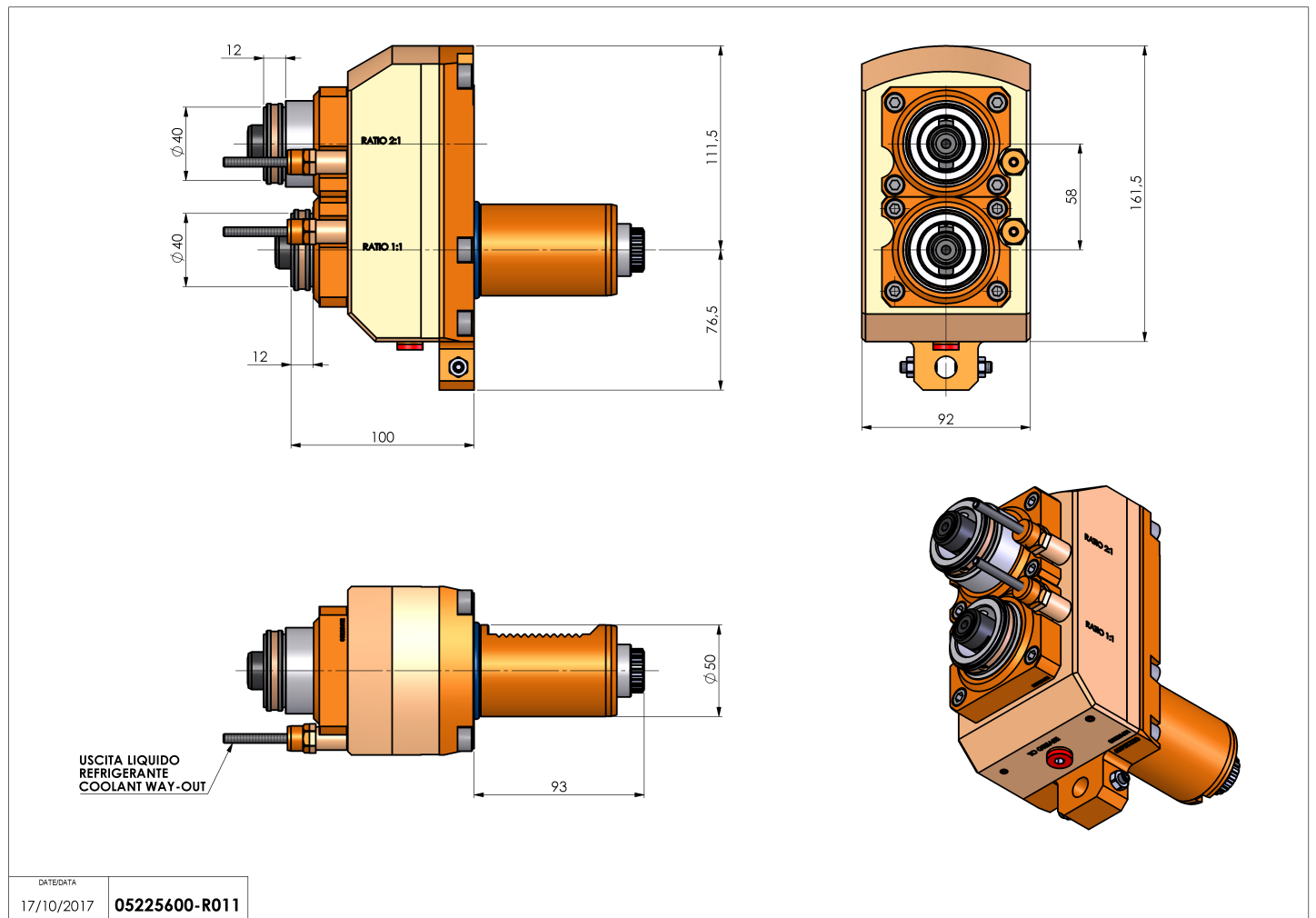

DATE/DATA	05225600-R011
17/10/2017	

Subject to technical changes