

05224500 - LT-A VDI50 ER40F2:1H110 5480SA

Type	LT-A Tool holder angle 90°
Mounting	VDI 50
Tool output	Collet nut ER 40 F - internal nut
Coolant	External coolant
Direction of rotation	r1 ↻ r2 ↻
Max speed [rpm]	in 4000 / out 2000
Max torque [Nm]	in 60 / out 120
Ratio	2:1
H [mm]	110
H1 [mm]	52
Accessories	N.A.
Notes	N.A.
Mounting tips	N.A.

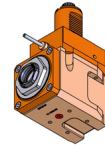

ATTENTION: CHECK THE ORIENTATION OF THE VDI TEETH

Always check live tool dimensions on the turret

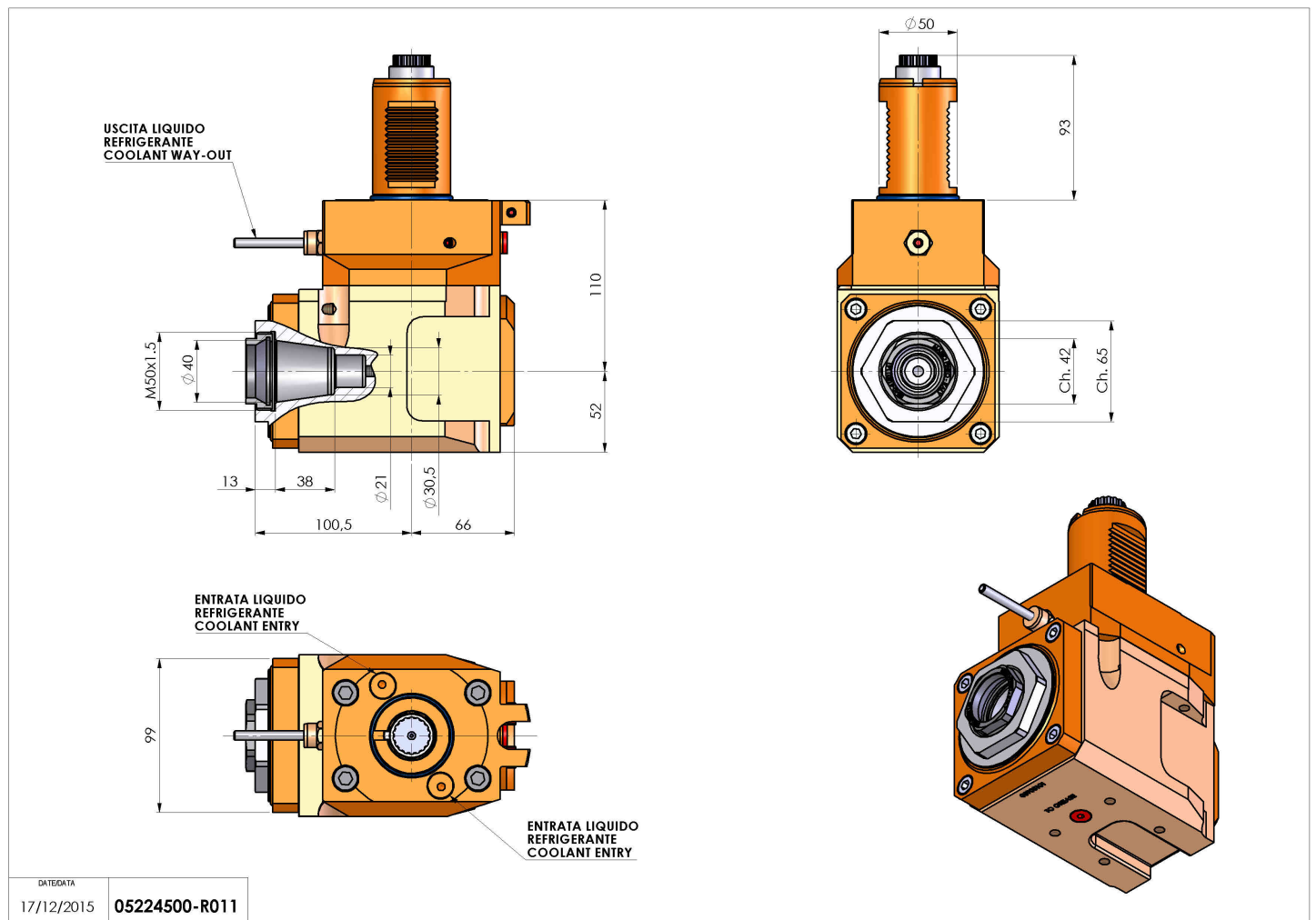

DATE/DATE	17/12/2015
	05224500-R011

Subject to technical changes