

05224300 - LT-S VDI50 ER40 RF H120 5480SA

Type	LT-S Tool holder straight
Mounting	VDI 50
Tool output	Collet nut ER 40
Coolant	Internal coolant
Direction of rotation	r1 ↻ r2 ↻
Max speed [rpm]	6000
Max torque [Nm]	120
Ratio	1:1
H [mm]	120
Max pressure [bar]	20
Accessories	
Notes	N.A.
Mounting tips	N.A.

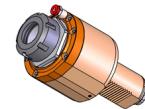

ATTENTION: CHECK THE ORIENTATION OF THE VDI TEETH

Always check live tool dimensions on the turret

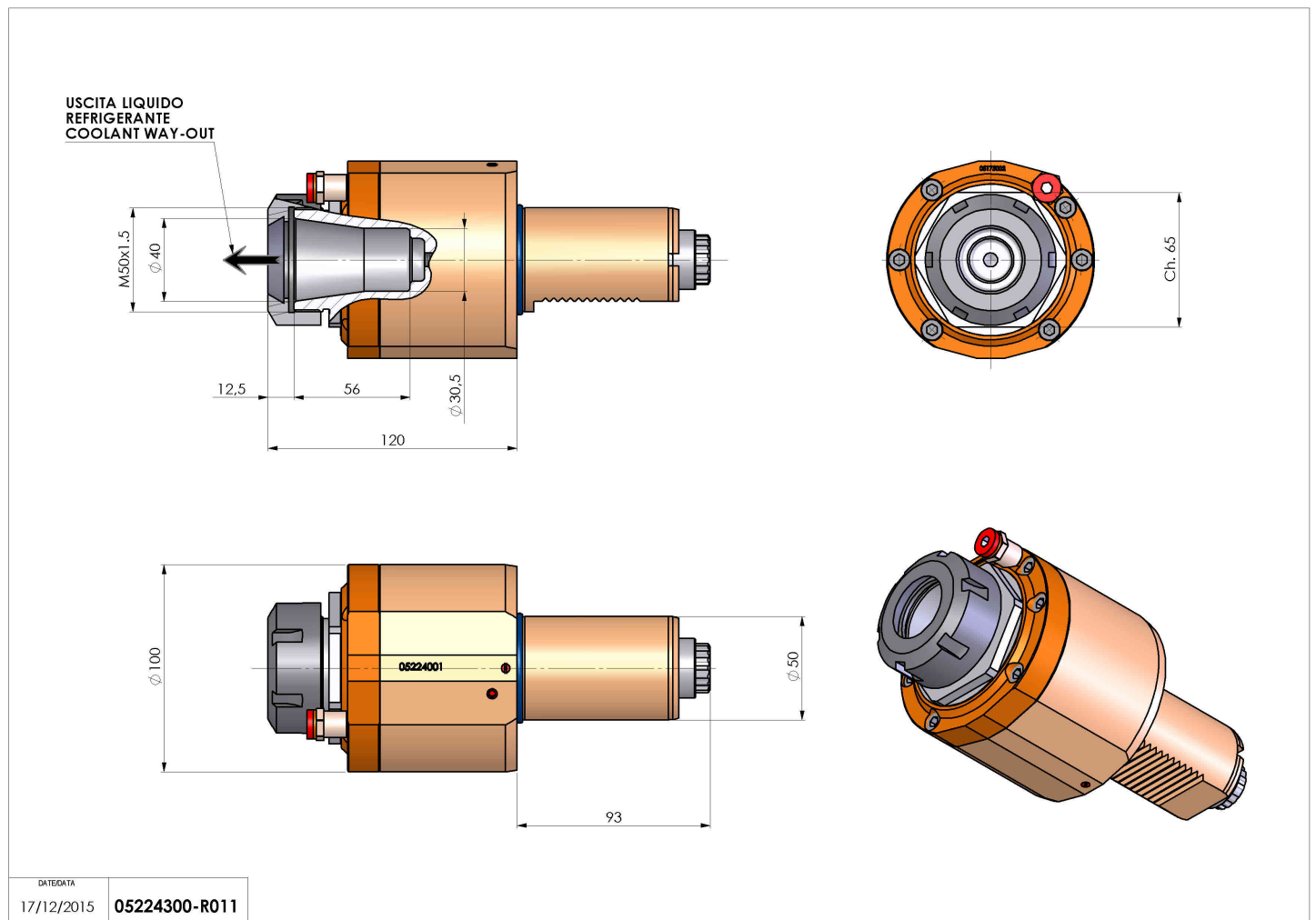

DATE/DATE	17/12/2015	05224300-R011
-----------	------------	---------------

Subject to technical changes