

# 05222600 - LT-A VDI40ER32 H100 L-R 5480SA

<b>Type</b>	LT-A Tool holder angle 90°
<b>Mounting</b>	VDI 40
<b>Tool output</b>	Collet nut ER 32
<b>Coolant</b>	External coolant
<b>Direction of rotation</b>	r1  r2
<b>Max speed [rpm]</b>	6000
<b>Max torque [Nm]</b>	63
<b>Ratio</b>	1:1
<b>H [mm]</b>	100
<b>H1 [mm]</b>	38
<b>Accessories</b>	N.A.
<b>Notes</b>	N.A.
<b>Mounting tips</b>	N.A.

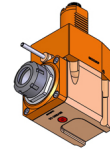

**ATTENTION: CHECK THE ORIENTATION OF THE VDI TEETH**

Always check live tool dimensions on the turret

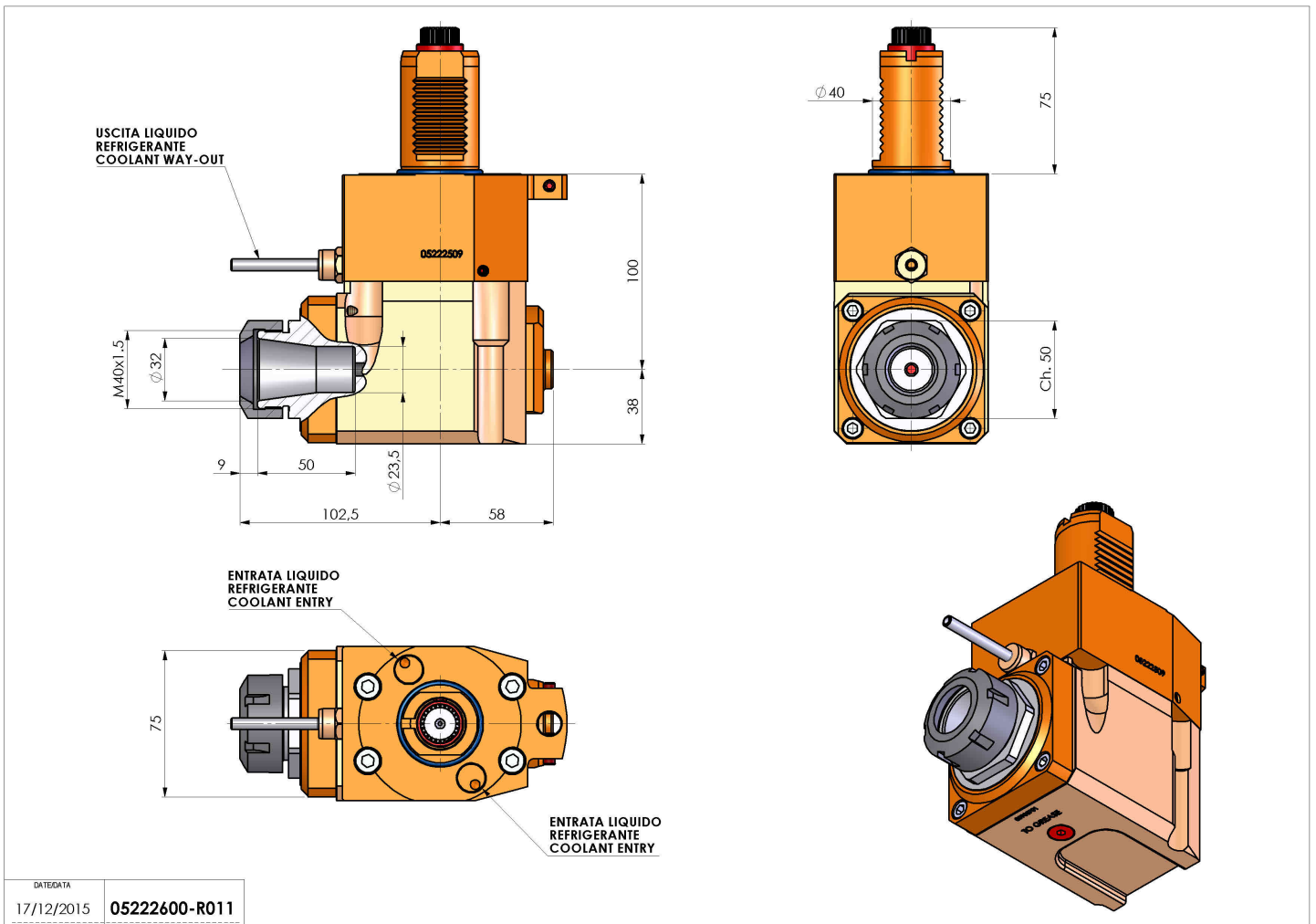

DATE DATA	17/12/2015	05222600-R011
-----------	------------	---------------

Subject to technical changes