



# 05222400 - LT-S VDI40 DIN22OFS2:1R H100SA

<b>Type</b>	LT-S OFS Tool holder straight offset
<b>Mounting</b>	VDI 40
<b>Tool output</b>	Shell-Mill DIN138 22
<b>Coolant</b>	External coolant
<b>Offset [mm]</b>	51
<b>Direction of rotation</b>	r1  r2 
<b>Max speed [rpm]</b>	in 4000 / out 2000
<b>Max torque [Nm]</b>	in 60 / out 120
<b>Ratio</b>	2:1
<b>H [mm]</b>	100
<b>Accessories</b>	N.A.
<b>Notes</b>	N.A.
<b>Mounting tips</b>	N.A.

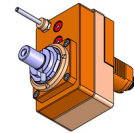

**ATTENTION: CHECK THE ORIENTATION OF THE VDI TEETH**

Always check live tool dimensions on the turret

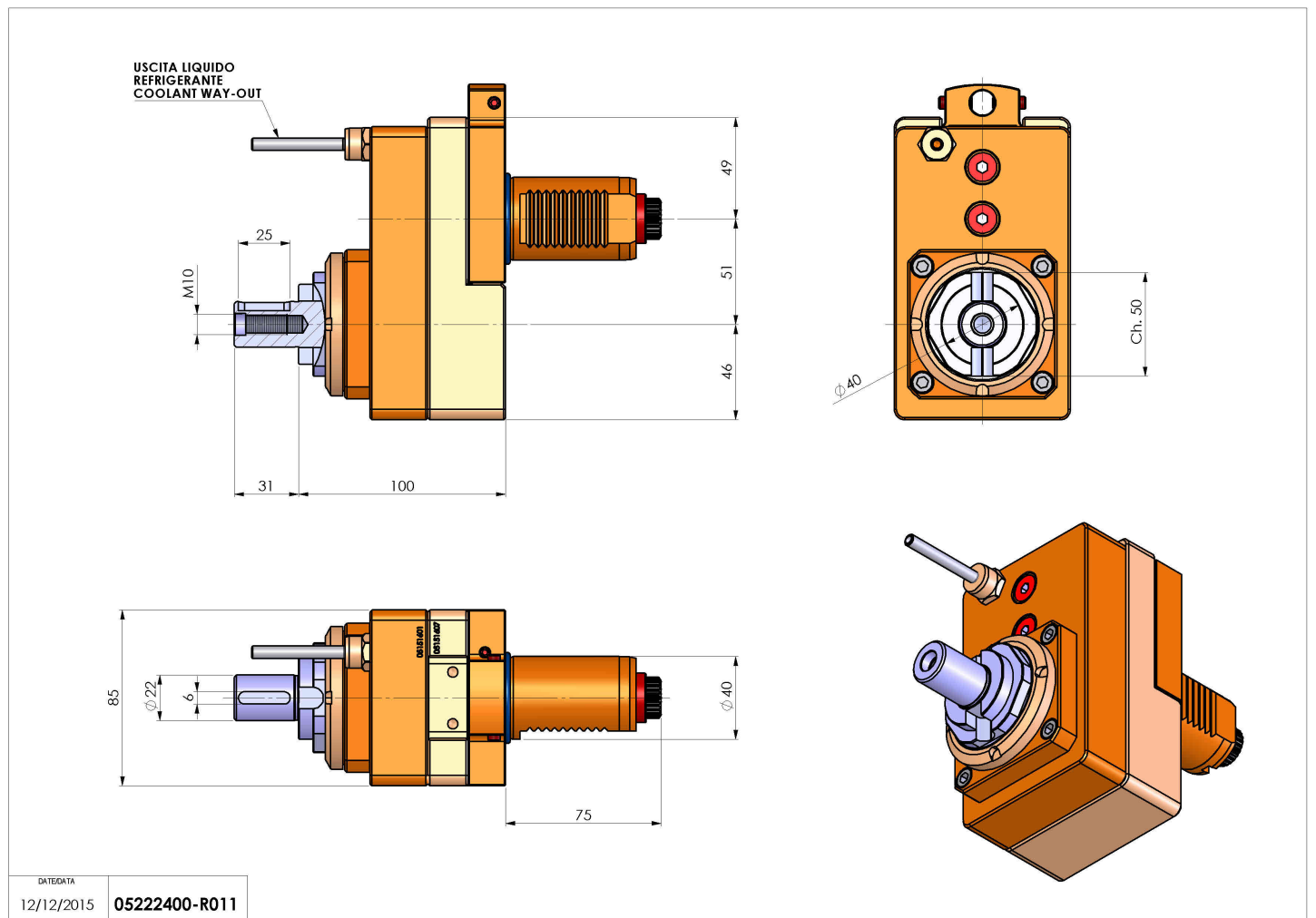

Subject to technical changes